

Road Planning and Design Manual
Edition 2: Volume 3

Supplement to Austroads Guide to Road Design
Part 4A: Unsignalised and Signalised Intersections

September 2025

Copyright

© The State of Queensland (Department of Transport and Main Roads) 2025.

Licence



This work is licensed by the State of Queensland (Department of Transport and Main Roads) under a Creative Commons Attribution (CC BY) 4.0 International licence.

CC BY licence summary statement

In essence, you are free to copy, communicate and adapt this work, as long as you attribute the work to the State of Queensland (Department of Transport and Main Roads). To view a copy of this licence, visit: <https://creativecommons.org/licenses/by/4.0/>

Translating and interpreting assistance



The Queensland Government is committed to providing accessible services to Queenslanders from all cultural and linguistic backgrounds. If you have difficulty understanding this publication and need a translator, please call the Translating and Interpreting Service (TIS National) on 13 14 50 and ask them to telephone the Queensland Department of Transport and Main Roads on 13 74 68.

Disclaimer

While every care has been taken in preparing this publication, the State of Queensland accepts no responsibility for decisions or actions taken as a result of any data, information, statement or advice, expressed or implied, contained within. To the best of our knowledge, the content was correct at the time of publishing.

Feedback

Please send your feedback regarding this document to: tmr.techdocs@tmr.qld.gov.au

Relationship with Austroads Guide to Road Design – Part 4A (2023)

The Department of Transport and Main Roads has, in principle, agreed to adopt the standards published in the Austroads *Guide to Road Design (2023) Part 4A: Unsignalised and Signalised Intersections*.

When reference is made to other parts of the Austroads *Guide to Road Design*, Austroads *Guide to Traffic Management*, Austroads *Guide to Road Safety* or Australian Standard AS 1742 *Manual of Uniform Traffic Control Devices*, the reader should also refer to Transport and Main Roads related manuals:

- *Road Planning and Design Manual (RPDM)*
- *Queensland Guide to Traffic Management (QGTM)*
- *Queensland Guide to Road Safety (QGRS)*
- *Queensland Manual of Uniform Traffic Control Devices (Queensland MUTCD)*, and
- *Traffic and Road Use Management (TRUM)* manual.

Where a section does not appear in the body of this supplement, the Austroads *Guide to Road Design – Part 4A* criteria is accepted unamended.

This supplement:

1. has precedence over the Austroads *Guide to Road Design – Part 4A* when applied in Queensland
2. details additional requirements, including *accepted with amendments* (additions or differences), *new* or *not accepted*, and
3. has the same structure (section numbering, headings and contents) as Austroads *Guide to Road Design – Part 4A*.

The following table summarises the relationship between the Austroads *Guide to Road Design – Part 4A* and this supplement using the following criteria:

Accepted	Where a section does not appear in the body of this supplement, the Austroads Guide to Road Design – Part 4A is accepted.
Accepted with amendments	Part or all of the section has been accepted with additions and/or differences.
New	There is no equivalent section in the Austroads Guide.
Not accepted	The section of the Austroads Guide is not accepted.

Relationship table

Section	Title	Queensland application	Department contact	
1	Introduction			
	1.1	Purpose	Accepted	Road Design
	1.2	Scope of this Part	Accepted	Road Design
	1.3	Design Criteria in Part 4	Accepted with amendments	Road Design
	1.4	Intersection Safety and the Safe System Approach	Accepted with amendments	Road Design
	1.5	Grade Separation of Traffic Movements	Accepted with amendments	Road Design
2	Layout Design Process			
	2.1	Design Process	Accepted with amendments	Road Design
	2.2	Alignment of Intersection Approaches	Accepted with amendments	Road Design
	2.3	Bicycles	New	Road Design
3	Sight Distance			
	3.1	General	Accepted	Road Design
	3.2	Sight Distance Requirements for Vehicles at Intersections	Accepted with amendments	Road Design
	3.3	Pedestrian Sight Distance Requirements	Accepted with amendments	Road Design
	3.4	Sight Distance at Property Entrances	Accepted with amendments	Road Design
4	Types of Intersection and their Selection			
	4.1	General	Accepted with amendments	Road Design
	4.2	Intersection Types	Accepted	Road Design
	4.3	Warrants for BA, AU and CH Turn Treatments	New	Road Design
	4.4	Median Turning Lanes or Two-Way Right-Turn Lanes (TWRTL) on an Urban Road	New	Road Design

Section	Title	Queensland application	Department contact	
5	Auxiliary Lanes			
	5.1	General	Accepted	Road Design
	5.2	Deceleration Lanes	Accepted with amendments	Road Design
	5.3	Acceleration Lane for Cars	Accepted with amendments	Road Design
	5.4	Acceleration Lane for Trucks	Accepted	Road Design
	5.5	Auxiliary Through-lane Design	Accepted with amendments	Road Design
	5.6	Other Considerations	Accepted	Road Design
6	Traffic Islands and Medians			
	6.1	Raised Traffic Islands and Medians	Accepted with amendments	Road Design
	6.2	Painted Traffic Islands and Medians	Accepted	Road Design
	6.3	Desirable Clearances to Traffic Islands and Medians	Accepted	Road Design
	6.4	Road Width between Kerbs and between Kerb and Safety Barrier	Accepted with amendments	Road Design
	6.5	Kerb and Channel	Accepted with amendments	Road Design
7	Right-turn Treatments			
	7	Right-turn Treatments	Accepted with amendments	Road Design
	7.1	Design Procedure	Accepted	Road Design
	7.2	Rural Right-turn Treatments – Undivided Roads	Accepted with amendments	Road Design
	7.3	Rural Right-turn Treatments – Divided Roads	Accepted	Road Design
	7.4	Rural Wide Median Treatment	Accepted with amendments	Road Design
	7.5	Urban Right-turn Treatments – Undivided Roads	Accepted	Road Design
	7.6	Urban Right-turn Treatments – Divided Roads	Accepted with amendments	Road Design
7.7	Right-turn Bans at Signalised Intersections	Accepted	Road Design	

Section	Title	Queensland application	Department contact
7.8	Right-turn Lanes for Cyclists	Accepted with amendments	Road Design
8	Left-turn Treatments		
8	Left-turn Treatments	Accepted with amendments	Road Design
8.1	General	Accepted with amendments	Road Design
8.2	Rural Left-turn Treatments	Accepted with amendments	Road Design
8.3	Urban Left-turn Treatments	Accepted with amendments	Road Design
9	U-Turn Treatments		
9.1	General	Accepted	Road Design
9.2	Rural Roads	Accepted	Road Design
9.3	Urban Roads	Accepted	Road Design
10	Signalised Intersections		
10.1	Design Process	Accepted with amendments	Road Design
10.2	Sight Distance	Accepted with amendments	Road Design
10.3	Signal Operation Considerations	Accepted with amendments	Road Design
10.4	Intersection Layouts	Accepted with amendments	Road Design
10.5	Traffic Lanes	Accepted	Road Design
10.6	Cyclist Lanes	Accepted with amendments	Road Design
10.7	Pedestrian Treatments	New	Road Design
	References		
	References	Accepted	Road Design

Section	Title	Queensland application	Department contact
Appendices			
A	Extended Design Domain (EDD) for Intersections	Accepted with amendments	Road Design
B	Truck Stability at Intersections	Accepted with amendments	Road Design
C	Swept Paths for Road Trains at High Entry Angle Left-turn Treatments	Accepted	Road Design
D	Basic Left-turn (BAL) Layouts at Rural Intersections	New	Road Design
Commentaries			
1		Accepted	Road Design
2		Accepted	Road Design
3		Accepted	Road Design
4		Accepted	Road Design
5		Accepted	Road Design
6		Not accepted	Road Design
7		Accepted	Road Design
8		Accepted	Road Design
9		Accepted	Road Design
10		New	Road Design

Departmental contacts

- Director (Road Design), Road Design, Hydraulics, Design and Spatial, Engineering and Technology, Transport and Main Roads email: roaddesignstandards@tmr.qld.gov.au.

Contents

Relationship with Austroads Guide to Road Design – Part 4A (2023)	i
Relationship table	ii
Departmental contacts	v
1 Introduction	1
1.3 Design Criteria in Part 4A	1
1.4 Intersection Safety and the Safe System Approach	1
1.5 Grade Separation of Traffic Movements	2
2 Layout Design Process	2
2.1 Design process	2
2.2 Alignment of intersection approaches	2
2.2.1 <i>Horizontal Alignment</i>	2
2.2.2 <i>Vertical Alignment</i>	3
2.3 Bicycles	3
3 Sight Distance	4
3.2.2 <i>Safe Intersection Sight Distance (SISD)</i>	4
3.3 Pedestrian Sight Distance Requirements	5
3.4 Sight Distance at Property Entrances	6
4 Types of Intersection and their Selection	6
4.1 General	6
4.3 Warrants for BA, AU and CH Turn Treatments	6
4.4 Median Turning Lanes or Two-Way Right-Turn Lanes (TWRTL) on an Urban Road.....	7
5 Auxiliary Lanes	9
5.2 Deceleration Lanes.....	9
5.2.2 <i>Determination of deceleration turning lane length</i>	9
5.3 Acceleration Lane for Cars	10
5.3.1 <i>General</i>	10
5.3.2 <i>Acceleration distance</i>	10
5.5 Auxiliary Through-lane Design	1
6 Traffic Islands and Medians	1
6.1 Raised Traffic Islands and Medians.....	1
6.1.1 <i>Raised islands</i>	1
6.1.3 <i>Raised high-entry angle and free-flow left-turn islands</i>	1
6.1.4 <i>Simple high entry angle design process</i>	2
6.4 Road Width between Kerbs and between Kerb and Safety Barrier.....	2
6.5 Kerb and Channel.....	3
6.5.1 <i>General</i>	3

7	Right-turn Treatments	3
7.2.2	<i>Auxiliary right-turn treatment (AUR)</i>	3
7.2.4	<i>Rural channelised T-junction – full length (CHR).....</i>	3
7.4	Rural Wide Median Treatment.....	4
7.6	Urban Right-turn Treatments – Divided Roads.....	5
7.6.1	<i>Channelised Right-turn (CHR) on divided urban roads</i>	5
7.8	Right-turn Lanes for Cyclists	5
8	Left-turn Treatments.....	5
8.1.3	<i>Sight distance requirements</i>	6
8.2	Rural Left-turn Treatments	7
8.2.1	<i>Rural Basic Left-turn treatment (BAL).....</i>	7
8.2.7	<i>Provision for cyclists at rural free flow left-turn lanes on bicycle routes</i>	8
8.3	Urban Left-turn Treatments.....	8
8.3.1	<i>Urban Basic Left-turn treatment (BAL).....</i>	8
8.3.3	<i>Urban Auxiliary Left-turn treatment (AUL) on the major road.....</i>	8
8.3.6	<i>Provision for cyclists at urban channelised treatments</i>	9
8.3.7	<i>Left-turn treatments for large vehicles</i>	9
10	Signalised Intersections	9
10.1	Design Process	9
10.2	Sight Distance	9
10.3	Signal Operation Considerations.....	10
10.3.1	<i>Traffic operation at an intersection</i>	10
10.4	Intersection Layouts	10
10.4.2	<i>Service road treatments</i>	11
10.6	Cyclists Facilities	12
10.6.1	<i>On-road bicycle lanes.....</i>	12
10.7	Pedestrian Treatments	13
	References	16
	Appendix A – Extended Design Domain (EDD) and Design Exception (DE) and potential mitigation strategies for intersections.....	18
A.1	General	18
A.2	EDD for sight distance at intersections.....	18
A.2.2	<i>Base and check cases</i>	18
A.2.5	<i>EDD Safe Intersection Sight Distance (SISD).....</i>	18
A.3	EDD for sight distances at domestic accesses	18
A.3.1	<i>Application of EDD for sight distances at domestic accesses.....</i>	18
A.5.7	<i>EDD for right-turn treatments on existing urban roads (S lanes).....</i>	19
A.5.8	<i>Turning lanes</i>	19
A.5.9	<i>Private accesses</i>	19

A.6	EDD treatment of a constrained left-turn radius.....	21
A.11	EDD warrants for intersection turn treatments	23
A.12	Island size	28
A.12.1	<i>Mitigation</i>	29
Appendix B	Truck Stability at Intersections	30
B.2	Lateral friction force on vehicles	30
Appendix D	Basic Left-Turn (BAL) Layouts at Rural Intersections	31
Commentary 6	35
Commentary 10	35

Tables

Table 3.3	– Walking speeds for elderly pedestrians.....	5
Table 5.3.2(a)	– Length of acceleration lanes for cars on level grade.....	10
Table 5.3.2(b)	– Correction of acceleration distances as a result of grade	12
Figure 10.4	– Late start for large corner islands.....	11
Table 10.4	– Minimum widths of raised medians.....	11
Figure 10.7(a)	– Intersection of pedestrian crossings	14
Figure 10.7(b)	– Treatment of pedestrian crossings.....	15

Figures

Figure 4.4	– Two-way right-turn lanes on an urban road.....	9
Figure 6.4	– Example of island treatments showing clearances at an intersection with single lane carriageways and no specific bicycle facilities	2
Figure A.5.8	– Example of private entrance widening - Hook right-turns	21
Figure A.6(a)	– Basic EDD Left-turn treatment (BAL) on an urban road.....	22
Figure A.6(b)	– Basic Left-turn treatment (BAL) on a rural road, side road < 50vpd AADT ..	23
Figure A.11(a)	– Warrants – Major road turn treatments – Extended Design Domain.....	25
Figure A.11(a)	(continued)	26
Figure A.11(b)	– Calculation of the major road traffic volume parameter ‘Q _M ’	27
Figure D(a)	– Details of type 'BAL' layout for rural sites to suit B-double operation.....	32
Figure D(b)	– Details of type 'BAL' layout for rural sites to suit type 1 (double) road train operation	33

Figure D(c) – Details of type 'BAL' layout for rural sites to suit type 2 (triple) road train operation	34
---	----

1 Introduction

1.3 Design Criteria in Part 4A

Difference

There is an editorial error in the 2nd sentence in the 2nd paragraph in Austroads *Guide to Road Design – Part 4A*. The sentence should read 'Appendix A contains Extended Design Domain (EDD) values...".

Addition

Guidance on the use of values outside of the Normal Design Domain (NDD) should be undertaken in accordance with Appendix A of the Transport and Main Roads *Road Planning and Design Manual 2nd Edition* (RPDM) Volume 3, Part 1.

1.4 Intersection Safety and the Safe System Approach

Addition

A Safe System approach to urban intersections is to design to optimise conditions for people walking and cycling. The key conflict is where a turning motor vehicle driver fails to give way and could hit a person continuing straight. Crash severity should be mitigated by designing for safer vehicle turning speed and improving observation angles. To achieve this, high-speed difference at conflict points should be avoided such as at channelised left-turns. Protected intersections with separated cycle tracks provide a safe intersection for all road users. Refer to Transport and Main Roads Guideline *Selection and Design of Cycle Tracks* for further information.

Transport and Main Roads Traffic Control (TC) Sign TC1775 is intended to warn other road users at junctions where motorcyclists have a history of being hit by turning traffic.

Speed has been identified as a major contributing factor to the occurrence and severity of many crashes at intersections. At rural intersections, this factor is exacerbated due to the high-speed differential between conflicting movements. Austroads *Methods for Reducing Speeds on Rural Roads – Compendium of Good Practice, AP-R449-14* describes methods for reducing speeds on rural roads and includes a range of treatments for application at rural intersections.

1.5 Grade Separation of Traffic Movements

Addition

At urban intersections, a Safe System outcome would be to provide grade separation, where appropriate, for vulnerable road users, for example, people walking and cycling, to eliminate conflicts with motorised vehicles (refer to Transport and Main Roads Guideline *Bicycle Rider and Pedestrian Underpasses*).

2 Layout Design Process

2.1 Design process

Addition

In Table 2.1 of Austroads *Guide to Road Design – Part 4A*, the term 'cycle tracks' is to be added to the 2nd line in the Key considerations column corresponding to the 4th row relating to Traffic lanes.

2.2 Alignment of intersection approaches

Addition

Treatments that reduce exposure, reduce the number of conflict points, encourage safe turning speeds, highlight conflict points and reduce impact speeds if the conflicts do occur, improve intersection safety for all road users.

Where motorised vehicles cross the path of people walking or cycling, high severity conflicts can result, even if the relative speed is low. For example, for people walking or cycling, the fatality risk when hit by a vehicle travelling at 50 km/h is twice as high as the risk at 40 km/h and is more than 5 times the risk compared to a vehicle travelling at 30 km/h at the conflict point. To reduce the severity if a crash occurs involving a vulnerable road user, urban intersection design should reduce the impact speed to as low as possible (<30 km/h). Some examples of how this might be achieved are shown in Transport and Main Roads Guidelines, *Selection and Design of Cycle Tracks* and *Raised Priority Crossings for Pedestrians and Cycle Paths*.

2.2.1 Horizontal Alignment

Addition

The alignment of intersecting roads at an intersection should preferably consist of a continuous curve of constant radius through the intersection (less desirable) with tangent points located at a distance no less than the equivalent in length of 2 seconds travel time at the design speed either side of the intersection.

2.2.2 Vertical Alignment

Addition

The vertical profile of the major road at the intersection should consider the following:

- Preferably be located within a sag curve with relatively gentle slopes to the intersection or on a section of relatively flat vertical grade.
- Where intersections are located on grades on the major road, the grade should preferably be less than 3% but can be accepted on grades of up to 6% with consideration given to the additional stopping / decelerating distance required in the downhill direction.
- Steeper grades can lead to problems with perception of the intersection in the uphill direction and stopping / deceleration issues in the downhill direction.
- If an intersection must be located within a large radius crest vertical curve, it can be located anywhere on the crest provided all sight distance parameters are met.
- Intersections located on short radii crest curves should be located at the apex of the crest (not either side) and preferably on a straight horizontal alignment. These locations apply only to brownfield locations.

2.3 Bicycles

There is no equivalent Section 2.3 in Austroads *Guide to Road Design – Part 4A*.

New

Intersections are areas of high conflict and can be difficult for cyclists to traverse. The following additional documents should be reviewed for additional specific design guidance for bicycles:

- Transport and Main Roads [Guidelines for Cyclists and Pedestrians](#)
- Transport and Main Roads *Traffic and Road Use Management* (TRUM) manual, and
- Transport and Main Roads *Queensland Guide to Traffic Management* (QGTM).

Transport and Main Roads requires the design for bicycles to be an integral part of the design of the various components of the road, not an 'add-on' after the basis for the design has been established.

In accordance with the Transport and Main Roads *Cycling Infrastructure Policy*, road upgrades are to incorporate 'cycle-friendly' designs. Along priority cycling routes, these cycle-friendly designs are marked cycle lanes, cycle paths, shared paths or other facilities for cyclists.

A 'cycle-friendly' design feature of urban intersections is the provision of 1 m minimum offsets from the edge of lane to kerb faces where there is no other provision for cyclists (e.g. there is no separate bicycle lane). This is to avoid cyclists having to negotiate 'squeeze points' at the intersection. On the major road in rural areas, the minimum offset is the greater of the shoulder width and 1 m.

If bicycle lanes are present either side of an intersection, specific cycle facilities are to be provided to guide cyclists through the intersection. Even a short-marked cycle lane through an intersection that does not provide route continuity may provide safety advantages to cyclists provided that its termination point does not lead cyclists into an unsafe situation.

Where there are a high number of cyclists or an intersection has a poor cycle safety record, a green coloured pavement surface for the cycle lane may deliver added cycle safety. Refer to Transport and Main Roads TRUM manual for guidance on the use of green coloured pavement surfaces.

Wide kerbside lanes enable greater separation of cyclists and motor vehicles, creating a higher level of safety and increased operational efficiency. Wide kerbside lanes should be carried through intersections to avoid 'squeeze points'.

Where a road is identified as a principal cycling route, a bike lane treatment on the uphill leg(s) may be appropriate to account for side-to-side movement of the bicycle and the large speed differential between bicycles and motorised vehicles uphill. A bicycle lane is also desirable on the downhill leg(s).

3 Sight Distance

3.2.2 Safe Intersection Sight Distance (SISD)

Addition

The time gaps provided by applying the SISD model are generally sufficient for heavy vehicles to undertake the following movements:

- left or right-turn from the minor road onto the major road
- through movement from the minor road at a cross intersection, and
- right-turn from the major road into the minor road.

However, the time gaps may not be sufficient for heavy vehicles to undertake these movements in particular circumstances, for example:

- where the design heavy vehicle is greater than a 19 m semi-trailer
- the major road is on a steep grade, and
- the major road comprises more than one lane in each direction.

Under such circumstances, advice from Transport and Main Roads' specialists should be sought as to whether the minimum values of SISD are sufficient to cover the particular heavy vehicle movements.

3.3 Pedestrian Sight Distance Requirements

Difference

The 4th sentence of the 2nd dot point is replaced with "CSD should be provided at crossings where the pedestrian does not have the priority."

Addition

Pedestrian walking speeds can vary significantly and are affected by age, sex, motivation, presence of other pedestrians and other traffic impediments. The distribution of free flow walking speeds varies as follows:

- minimum walking speed 0.74 m/s
- maximum walking speed 2.39 m/s
- maximum speed of wheelchairs 10 km/h = 2.78 m/s (wheelchairs are classified as pedestrians in legislation), and
- average unimpeded free-flow 1.35 m/s walking speed.

Calculation of green time at traffic signals is based on an average design walking speed of 1.2 m/s, but this is still faster than some pedestrians can manage. Elderly pedestrians often adopt significantly lower speeds than the younger part of the population. Table 3.3 provides guidance on the walking speed to adopt for various circumstances.

Table 3.3 – Walking speeds for elderly pedestrians

Walking Pace	Mean Speed (m/s)	10th Percentile Speed (m/s)
Normal	1.13	0.8
Hurried	1.41	1.0
Rushing	1.71	1.0

3.4 Sight Distance at Property Entrances

Addition

In existing constrained situations where it is deemed impractical to achieve the sight distance criteria as described in *Austroads Guide to Road Design – Part 4A*, it should be sought, as a minimum, to comply with the sight distance criteria as per Section 3.2.4 of Australian Standard AS 2890.1 *Parking facilities – Off-street car parking*.

At many properties (for example, major shopping centres), the entrance may appear to a driver to be an intersection as opposed to the more common form of a property entrance. Due to the variety of different designs and pavement / kerb treatments that can be used at property entrances, no clear distinction can be made as to what is an intersection and what is a property entrance.

In considering the sight distance requirements to be applied at a property entrance, a judgement is to be made on the basis that if drivers are likely to consider that a property entrance looks like an intersection, then it should be designed in accordance with the requirements for an intersection.

4 Types of Intersection and their Selection

4.1 General

Addition

Where urban roundabouts or signalised intersections are located on a bicycle route, protected intersections and cycle tracks should be considered (refer to Section 4 of Transport and Main Roads Guideline *Selection and Design of Cycle Tracks*).

4.3 Warrants for BA, AU and CH Turn Treatments

There is no equivalent Section 4.3 in *Austroads Guide to Road Design – Part 4A*.

New

Many lower-order existing intersections on Two-Lane Two-Way (2L2W) roads have historically been constructed without any widening and do not meet the minimum design layout for a Basic Right-turn (BAR) / Basic Left-turn (BAL). These intersections are referred to as Simple Right (SR) and Simple Left (SL) intersections.

The warrants shown in *Austroads Guide to Traffic Management – Part 6* are for greenfield sites (i.e. new intersections on new roads). These warrants are to be applied as Normal Design Domain (NDD) for the selection of the preferred intersection type at any intersection. The warrants provide guidance on where a full-length deceleration lane must be used, and where a shorter lane, Auxiliary Left-turn Short [AUL(S)] and Channelised Right-turn Short [CHR(S)], may be acceptable based on traffic volume.

The warrants do not consider the presence of priority crossings on side roads. Where priority crossings are provided adjacent to higher speed, higher volume roads, a higher level of provision than indicated by the warrants may be justifiable.

At intersections on 2L2W, the minimum turn treatment shall be a BAR / BAL. SR / SL intersection types are not to be constructed at new intersections on new roads. The preferred minimum intersection turn treatment on major roads and highways is a CHR(S) / AUL(S) due to the combination of operational and safety issues.

Where a high volume of left turning traffic is present on high-speed rural roads, sight lines must not be obscured for traffic entering from the minor road. Depending on sight lines and traffic volumes, left-turn lanes may need to be repositioned or channelised.

Auxiliary Right-turn Lane (AUR) treatments are not to be constructed at new intersections and existing AURs are to be replaced with at least a CHR(S).

On Four-Lane Two-Way (4L2W) and Six-Lane Two-Way (6L2W) roads, the minimum turn treatment shall be a CHR(S) / BAL. At new 4 and 6 lane roads, it is preferred practice that a median of sufficient width would be included to accommodate a CHR(S) or CHR treatment at every intersection, allowing a right-turn from the major road.

An EDD version of these warrants for potential application at constrained and brownfield sites is provided in Appendix A.11. Further commentary on the methodology behind these warrants is provided in Commentary 10.

4.4 Median Turning Lanes or Two-Way Right-Turn Lanes (TWRTL) on an Urban Road

There is no equivalent Section 4.4 in *Austroads Guide to Road Design – Part 4A*.

New

Median Turning Lanes or Two-Way Right-turn Lanes (TWRTL) can be used to maintain capacity and level of service for the through-lanes by removing the obstruction caused by a right-turning vehicle. It has the added advantage of providing shelter for vehicles both entering and exiting from an access. A diagram of such a treatment is shown in Figure 4.4.

This treatment is particularly applicable in commercial and residential areas with closely spaced access points. It has been used successfully where arterial roads bisect country town business and industrial areas and access is required for motels, service centres commercial establishments and adjoining low traffic volume side streets.

TWRTLs should not be introduced without consideration of existing and future land use. They should not be allowed to provide unlimited and uncontrolled right-turn movements. However, when used on roads with traffic signal control, TWRTLs may provide sufficient gaps to adequately service low volume side properties with efficiency and safety. In non-access controlled areas, they can encourage ad-hoc land development with inappropriate accesses provided at developments.

On new heavily travelled arterial roads and commercial and industrial areas with widely spaced access points, median control of right-turn movements is preferred.

TWRTLs should be restricted to the urban environment with travel speeds of 70 km/h or less. They should not be used in high density residential areas due to the potential conflict with uncontrolled pedestrian movements.

A TWRTL must not be used in conjunction with an intersection. The ends of the TWRTL treatment must not be closer than 10 m from the start of any right-turn lane at an intersection.

The through road should have no more than 2 lanes in each direction, resulting in a total of 5 lanes with the introduction of a TWRTL.

Geometric considerations

The TWRTL is to be paved flush with the adjacent lanes. To improve the definition of the lane, a different coloured pavement material other than red (Bus Only lanes) or green (Cycle lanes) can be used. The desirable width is 3 m to 4.8 m. TWRTLs and right-turn auxiliary lanes within the same length of median must be separated by a raised island and adequately sign posted.

Figure 4.4 – Two-way right-turn lanes on an urban road

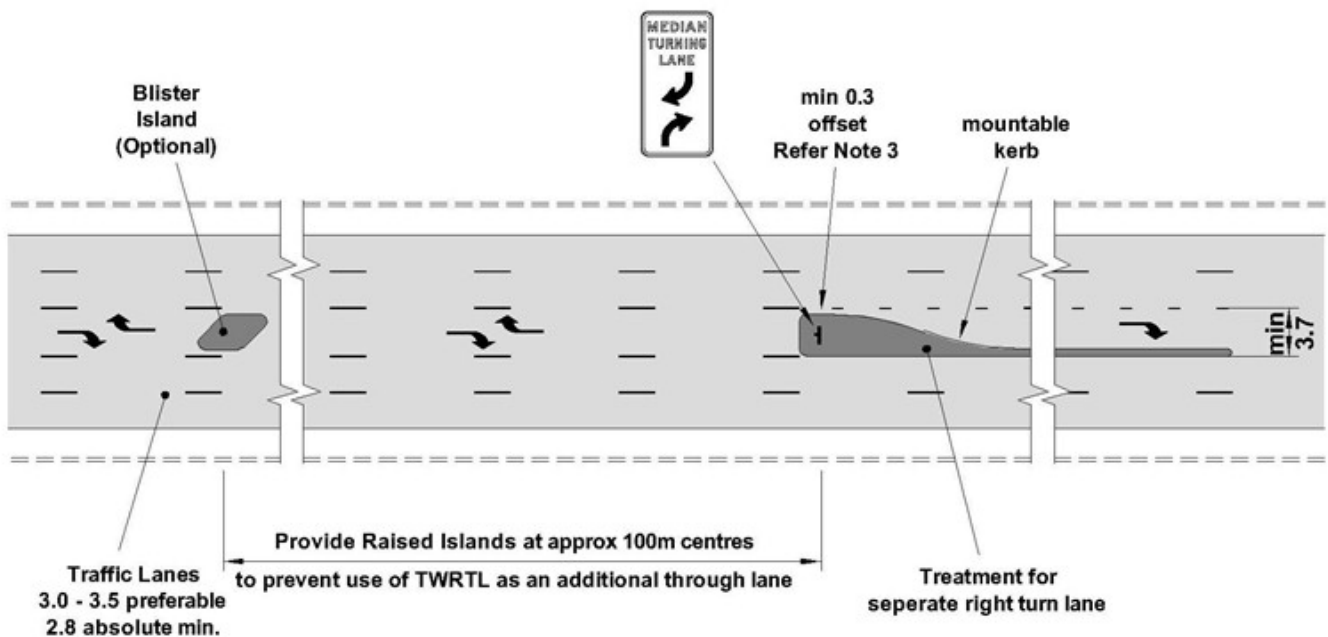

Notes:

1. This diagram does not show any specific bicycle facilities. Where specific bicycle facilities are required (e.g. exclusive bicycle lanes), refer to Austroads *Cycling Aspects of Austroads Guides AP-G88-17*.
2. See Queensland MUTCD for linemarking, spacing of pavement arrows, advance warning and regulatory signs.
3. Diagram shows 2 lanes in each direction, but this treatment can be used for roads with a single lane in each direction.

5 Auxiliary Lanes

5.2 Deceleration Lanes

5.2.2 Determination of deceleration turning lane length

Addition

Low to moderate speed urban arterial road intersections

Where the entry to the auxiliary left lane crosses a bicycle lane on the approach to an urban intersection, a high-speed conflict area can result in high severity rear-end and side-swipe crashes. In urban areas, this conflict can be avoided by designing a transition from bicycle lane to cycle track and a protected intersection (refer to Section 4 of Transport and Main Roads Guideline *Selection and Design of Cycle Tracks*).

5.3 Acceleration Lane for Cars

5.3.1 General

Addition

Note added to Figure 5.4 of *Austroads Guide to Road Design – Part 4A*. The emergency run-off area is to be designed as per the requirements detailed in Section 9.9.2 of RPDM Volume 3, Part 3.

At intersections on urban roads where people are likely to be walking or cycling, free flow acceleration lanes can result in conflicts, therefore it is recommended in such situations to consider alternative turn treatments. Transport and Main Roads Guideline *Selection and Design of Cycle Tracks* presents intersection forms which mitigate the risk associated with conflicts for cyclists.

5.3.2 Acceleration distance

Difference

All references to Table 5.5 and Table 5.6 in this section of *Austroads Guide to Road Design – Part 4A* are to be replaced respectively with references to Tables 5.3.2(a) and 5.3.2(b).

Replace 'Table 5.5: Length of acceleration lanes for cars on a level grade' (and associated notes) with Table 5.3.2(a) (and associated notes).

Table 5.3.2(a) – Length of acceleration lanes for cars on level grade

Design speed of road entered ¹ (km/h)	Length of acceleration lane A (m) (including length of merge taper) – for flat grade								4 sec travel (m)	Merge T_M (M)	Min desirable length 4 sec + T_M^3
	Design speed of entry curve (km/h)										
	0 ²	20	30	40	50	60	70	80			
50	70	60	50	30	-	-	-	-	55	50	105
60	100	95	85	65	35	-	-	-	65	60	125
70	140	135	125	105	75	45	-	-	80	70	150
80	215	205	195	175	150	115	75	-	90	80	170
90	300	295	280	265	235	200	160	90	100	90	190
100	405	395	385	365	340	305	265	195	110	100	210
110	600	590	580	560	535	500	460	385	120	105	225

Notes:

1. For the purpose of calculating the acceleration lane lengths at intersections, the speed reached is usually made equal to the mean free speed of the through road as defined in RPDM Volume 3, Part 3. In the absence of local data, it can be assumed that the mean free speed is approximately equal to the speed limit.

2. Length required where a vehicle accelerates from a zero speed.
3. Minimum desirable values have been rounded.

General Notes:

- Values in the non-shaded areas are based on the distance required to accelerate from the turning speed to the mean free speed of the road being entered.
- For values in the green-shaded areas, adopt the minimum desirable length, as in this area of the table these values are greater than the distance to accelerate from the turning speed to the design speed of the road being entered.
- Values shown in table are for level grade. Adjust for grade using Table 5.3.2(b). Flat grade is any road with a grade given by $1\% \text{ downgrade} \leq \text{grade} \leq 1\% \text{ upgrade}$.

The values in Tables 4A-2 and 4A-3 have been generated from VEHSIM acceleration curves for a typical car. The VEHSIM curves are reproduced in Commentary 8 of RPDM Volume 3 Part 4C.

In practice, the vertical profile of an acceleration lane may consist of sections of varying grade due to design issues such as the natural topography or other constraints. In these situations, the overall length of the acceleration lane required can be established by determining the vehicle speed at the start of the final section of grade, and determining the remaining length required for vehicles to meet the required design speed. A worked example of determining lane lengths on compound grades is included in Commentary 8 of RPDM Volume 3 Part 4C.

Replace Table 5.6: Correction of acceleration distances as a result of grade and associated notes with Table 5.3.2(b) (and associated notes).

Table 5.3.2(b) – Correction of acceleration distances as a result of grade

Design speed ¹ of road entered (km/h)	Ratio of acceleration length on grade to acceleration length on level (Table 5.3.2(a))															
	Design speed of turning roadway curve (km/h)															
	1% < upgrade ≤ 3%								1% < downgrade ≤ 3%							
	0	20	30	40	50	60	70	80	0	20	30	40	50	60	70	80
50	1.05	1.10	1.10	1.15					0.95	0.90	0.90	1.00				
60	1.10	1.10	1.05	1.10	1.15				0.95	0.95	0.90	0.90	1.00			
70	1.15	1.10	1.10	1.15	1.20	1.10			0.95	0.95	0.90	0.90	0.95	0.90		
80	1.15	1.15	1.15	1.15	1.15	1.15	1.15		0.90	0.90	0.85	0.90	0.85	0.85	0.80	
90	1.20	1.15	1.20	1.20	1.20	1.25	1.20	1.30	0.90	0.85	0.90	0.85	0.85	0.85	0.80	0.85
100	1.20	1.20	1.20	1.20	1.20	1.25	1.25	1.25	0.85	0.85	0.85	0.85	0.85	0.85	0.85	0.80
110	1.40	1.40	1.40	1.45	1.45	1.45	1.50	1.55	0.80	0.80	0.80	0.80	0.80	0.75	0.75	0.75

	3% < upgrade ≤ 5%								3% < downgrade ≤ 5%							
50	1.15	1.15	1.20	1.35					0.85	0.90	0.80	0.85				
60	1.25	1.20	1.25	1.25	1.30				0.90	0.85	0.80	0.75	0.85			
70	1.25	1.25	1.30	1.30	1.30	1.30			0.90	0.85	0.85	0.80	0.80	0.80		
80	1.35	1.40	1.40	1.45	1.45	1.50	1.60		0.80	0.80	0.75	0.75	0.75	0.75	0.65	
90	1.45	1.45	1.50	1.50	1.55	1.60	1.70	1.70	0.80	0.75	0.75	0.75	0.75	0.75	0.70	0.70
100	1.55	1.55	1.55	1.60	1.60	1.65	1.70	1.70	0.75	0.75	0.75	0.75	0.75	0.70	0.70	0.70
110 ²									0.70	0.70	0.65	0.65	0.65	0.65	0.65	0.60

	5% < upgrade ≤ 6%								5% < downgrade ≤ 6%							
50	1.30	1.35	1.40	1.50					0.85	0.85	0.80	0.85				
60	1.40	1.35	1.40	1.45	1.55				0.85	0.85	0.80	0.75	0.85			
70	1.45	1.45	1.45	1.50	1.55	1.55			0.80	0.80	0.80	0.80	0.80	0.80		
80	1.75	1.80	1.80	1.90	1.95	2.10	2.40		0.75	0.75	0.70	0.70	0.70	0.65	0.60	
90	2.00	2.00	2.10	2.10	2.20	2.35	2.55	2.55	0.70	0.70	0.70	0.70	0.65	0.65	0.60	0.60
100	2.15	2.20	2.20	2.25	2.30	2.40	2.55	2.55	0.70	0.70	0.70	0.65	0.65	0.65	0.60	0.60
110²									0.60	0.60	0.60	0.60	0.55	0.55	0.55	0.55

Notes:

1. For the purpose of calculating the acceleration lane lengths at intersections, the speed reached is usually made equal to the mean free speed of the through road as defined in RPDM Volume 3, Part 3 *Geometric Design*. In the absence of local data, it can be assumed that the mean free speed is approximately equal to the speed limit, and
2. Empty cells at these speeds indicate that the modelled acceleration does not result in vehicles reaching 110 km/h. In these cases, the acceleration lanes should be converted to an added lane.

General Notes:

- Values in the non-shaded areas are based on the distance required to accelerate from the turning speed to the design speed of the road being entered, and
- For values in the green-shaded areas, adopt the minimum desirable length from Table 5.3.2(a), as in this area of the table these values are greater than the grade corrected distance to accelerate from the turning speed to the design speed of the road being entered.

5.5 Auxiliary Through-lane Design

Addition

The start and termination points of an auxiliary lane should be clearly visible to approaching drivers in accordance with the sight distance requirements outline in Table 9.7 in *Austroads Guide to Road Design – Part 3* and the additional considerations for merge points discussed in Section 5.3.4.

The department requires that a run-out area be provided for the merge area of all auxiliary lanes.

6 Traffic Islands and Medians

6.1 Raised Traffic Islands and Medians

6.1.1 Raised islands

Addition

Semi-mountable kerbs are preferred for raised islands and medians, however, in some locations, a barrier kerb type may be appropriate. Guidance on the selection and application of the various kerb types is discussed in Table 6.2 of *Austroads Guide to Road Design – Part 4A*. Further information on kerb types and their application in Queensland is detailed in RPDM Volume 3, Part 3.

Islands at intersections should be designed to suit turning paths of design vehicles and may need to consider the use of mountable islands in some circumstances. The design of the islands should ensure that the continuity of the major road through the intersection is maintained and is legible for approaching drivers.

6.1.3 Raised high-entry angle and free-flow left-turn islands

Addition

At intersections on urban roads where people are likely to be walking or cycling, high-entry angle treatments and free-flow acceleration lanes can result in conflict, therefore in such situations consideration should be given to alternative turn treatments. Transport and Main Roads Guideline *Selection and Design of Cycle Tracks* presents intersection forms which mitigate the risk associated with conflicts for cyclists. For left-turn treatment selection in Queensland, refer to QGTM Part 6.

Channelised left-turns are not appropriate where cycle tracks continue through an urban protected intersection (refer to Transport and Main Roads Guideline *Selection and Design of Cycle Tracks*).

6.1.4 Simple high entry angle design process

For left-turn treatment selection in Queensland, refer to QGTM Part 6.

6.4 Road Width between Kerbs and between Kerb and Safety Barrier

Addition

Figure 6.4 shows how to provide for the design vehicle swept paths at an intersection comprising of single lane carriageways.

Figure 6.4 – Example of island treatments showing clearances at an intersection with single lane carriageways and no specific bicycle facilities

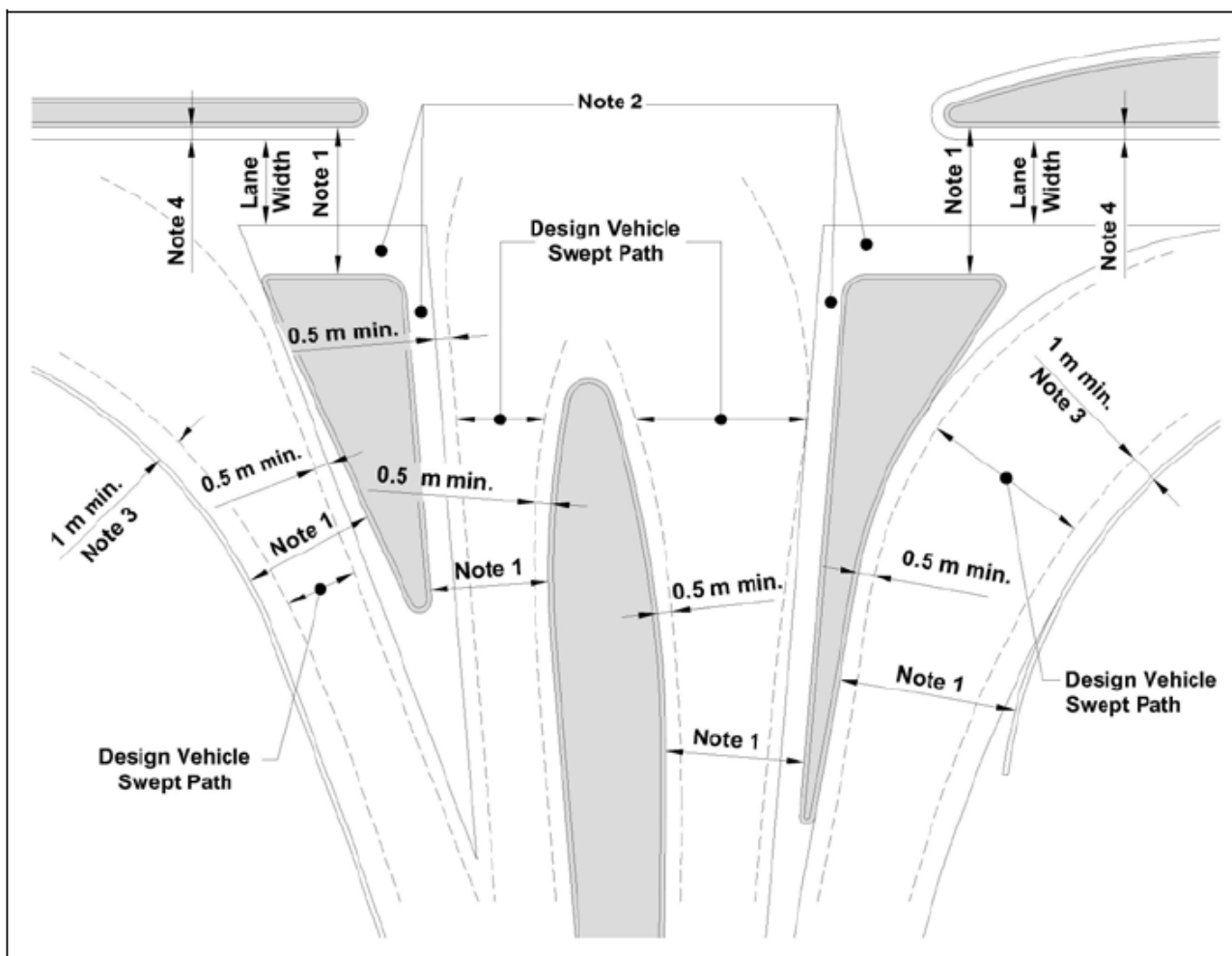

Notes:

1. Minimum desirable width between kerbs to allow for a broken-down vehicle is 5 m. This width is not mandatory if other provisions for passing broken-down vehicles are provided. Such provisions may include mountable or semi-mountable kerbing on islands / medians with sufficient offset to hardware (e.g. signs, light poles and traffic signal posts) to allow a very slow passing manoeuvre.
2. Offsets between raised islands and adjacent edge lines are given in Table 6.5 of *Austroads Guide to Road Design – Part 4A*. As no specific bicycle facilities exist in this example, a minimum 1 m offset should cater for bicycles in urban areas. The 1 m offset provides the capabilities listed in

Note 3. On the major road in rural areas, the minimum offset must be the greater of the shoulder width and 1 m.

3. The 1 m offset provides:
 - a. clearance from the kerb to the design vehicle swept path
 - b. additional width for the check vehicle, and
 - c. provision for cyclists.
4. This diagram shows an intersection with no specific bicycle facilities. For intersections with specific bicycle facilities (e.g. exclusive bicycle lanes), refer to Section 10.6.

6.5 Kerb and Channel

6.5.1 General

Addition

Add the following bullet point to the third paragraph of Austroads *Guide to Road Design – Part 4A*:

- to separate cycle tracks from motor vehicle lanes.

7 Right-turn Treatments

Addition

Motorcycle and cyclist risks should also be considered in determining the preferred layout for right-turns at a site. These road users are more difficult to see and, when stopped waiting to turn right from the major road, are at increased risk of rear-end crashes. There is also likely to be an increased risk of motorcyclists and cyclists accepting smaller gaps in traffic due to the perceived risk of rear-end crashes.

At locations with high volumes of motorcycle / cyclist traffic, CHR treatment to provide additional protection to vehicles making the right-turn movement should be considered.

7.2.2 Auxiliary right-turn treatment (AUR)

Addition

Auxiliary Right-turn Lane (AUR) treatments are not to be constructed at new intersections and existing AURs are to be replaced with at least a CHR(S).

7.2.4 Rural channelised T-junction – full length (CHR)

Addition

Channelisation has particular application in the following areas:

- Intersections at odd angles (Y-junctions, skewed crossroads) or multi-leg intersections (generally only appropriate if the intersection is realigned and/or if traffic signal control is used).

- Sites where turning traffic movements are particularly heavy.
- Locations where the safety record of an intersection is shown to be susceptible to particular crash types, such as opposing side-swipe and head-on crashes, right-turn opposing, and high-speed rear-end collisions.
- Sites where a refuge area for pedestrians is desirable.
- Sites where unusual manoeuvres are occurring, or where unwanted movements are to be eliminated. A channelised layout may be the only solution appropriate at some sites. These include some multi-lane divided roads, and sites where it is necessary to provide positive protection of the furniture (signs, traffic signal posts etc) associated with the form of traffic control adopted.

The associated furniture (particularly raised medians) can be regarded as a hazard, which means the increased risk must be clearly outweighed by other advantages.

All channelised intersections with raised medians and kerbed islands must be lit in accordance with the standards set out in RPDM Volume 6 *Lighting*.

Channelised intersections always require good sight distance to the starting point of the median (especially raised). The median or island may have to be extended to meet this requirement. A few large islands are always preferable to a large number of small islands.

Drainage of raised medians and islands can be expensive. Regular sweeping may be necessary.

Where traffic volumes are high, the number of approach lanes, including auxiliary lanes, will increase, and channelisation (in some form) becomes inevitable. Preliminary approach lane requirements may be assessed using the techniques outlined in Austroads *Guide to Traffic Management – Part 3*. Detailed design requirements for medians and islands are given in Section 6.

7.4 Rural Wide Median Treatment

Addition

Wide median treatments are discussed in Section 3.2.9 of Austroads *Guide to Traffic Management – Part 6*. These treatments, even in isolated locations, can be confusing with drivers mistaking the intersection for a roundabout. This can potentially lead to hazardous situations where traffic travelling across the median (right-turning traffic from the major road and through / right traffic from the minor road) may fail to give way to through traffic on the opposing major road. In these cases, designers should consider additional measures to further alert drivers that the wide median treatment is not a roundabout. These measures may include additional and larger signage, particularly at the give way lines within the median treatment.

7.6 Urban Right-turn Treatments – Divided Roads

7.6.1 Channelised Right-turn (CHR) on divided urban roads

Addition

Consideration should be given to the suitability of unsignalised channelised right-turn treatments on divided urban roads if nearby signalised alternatives exist. The unsignalised treatment can require complex gap selection in multiple streams of fast and slow moving road users and may be best avoided in these circumstances.

7.8 Right-turn Lanes for Cyclists

Right-turn lanes for cyclists are generally not provided where a cyclist would need to cross 2 or more lanes to access the facility. In this case, a hook-turn storage box may be provided to accommodate the right-turn for cyclists (refer to Section 10.6 of *Austroads Guide to Road Design – Part 4A* for further details on hook-turns).

8 Left-turn Treatments

Addition

CHR turn treatments record much lower crash rates than BAR and AUR turn treatments but are not significantly different than CHR(S) treatments. CHL treatments record a slightly higher crash rate than BAL treatments, but the increase is not significant. Therefore, warrants for CHL turn treatments should not be selected on the basis of safety. Instead, they may be justified by circumstances such as:

- Improving capacity and delays at the intersection.
- Improving safety for other conflict types. For left-turn treatment selection in Queensland, refer to QGTM Part 6 and Transport and Main Roads Guideline *Selection and Design of Cycle Tracks*.
- Changing the give way rule in favour of other manoeuvres at the intersection, and
- Defining more appropriately the driving path by reducing the area of bitumen surfacing, especially at skewed intersections catering for large and over dimensional vehicles.

8.1.3 Sight distance requirements

There is no equivalent Section 8.1.3 in Austroads *Guide to Road Design – Part 4A*.

New

In existing situations, where sighting requirements to approaching vehicles are below the criteria explained in Sections 3.2 and Commentary 1, the following remedial treatments should be considered:

a) Reconstruction

Reconstruction of the left-turn to overcome sighting problems may be an option. By providing a protected acceleration lane on the departure side of the turn, observation angle criteria are no longer applicable and are replaced by merging requirements.

Generally, acceleration lanes are associated with multi radii (3 centred curve) returns. If a left-turn slip lane exists without a protected acceleration lane, and the observation angle exceeds 120°, reconstruction to a high entry angle turn may be appropriate.

Elimination of the slip lane and provision of a single radius return may be appropriate, depending upon capacity requirements.

Relocation of an intersection to overcome sighting problems is generally more practical in rural areas than in urban situations.

b) Reduce approach speed

The traffic speed on the priority road is reduced to ensure that the available sight distance meets sight requirements. This is generally only possible on local streets where effective speed control measures, such as speed humps, thresholds, or similar forms of speed control, can be introduced.

On collector, sub arterial and arterial roads, speed reduction can be achieved with a roundabout (mostly urban application), but different sight requirements will then apply. However, roundabouts can create problems where there are high volumes of other road users (e.g. motorcyclists, pedestrians and cyclists). Roundabouts should not be used solely as a speed control device to remedy sight distance deficiencies.

Speed zoning over short, isolated lengths is undesirable and must be done in accordance with the *Queensland Road Safety Technical User Volumes (QRSTUV): Guide to Speed Management*.

c) Provide traffic signals

Traffic signals can be used to resolve safety problems when sight distances are deficient. This solution can be costly and network consequences must be carefully examined (particularly in terms of delay). However, note that sight distance requirements are still applicable at intersections controlled by traffic signals (refer to Section 10.2).

d) Banning the turn

This is the final available option and should only be applied when convenient alternative access is available and the effect on the road network acceptable. Banning a left-turn out of a minor road can only be effectively achieved by banning all movements turning out of the minor road.

8.2 Rural Left-turn Treatments

8.2.1 Rural Basic Left-turn treatment (BAL)

Addition

Figure 8.2 in *Austroads Guide to Road Design – Part 4A* shows a widened shoulder for movements from the major to minor road which is based on a left-turning vehicle having a speed reduction of 30% in the through-lane, prior to moving onto the shoulder and decelerating. This is based on the assumption that drivers decelerate at a maximum value of 3.5 m/s^2 ($d = 0.36$) from the start of the taper to the start of the kerb return. The total width of through-lane plus widened shoulder is a minimum of 6 m.

Figure 8.2 in *Austroads Guide to Road Design – Part 4A* also shows an optional kerb return, which can provide the following advantages:

- better perception of the intersection, especially for intersections with limited visibility
- reduce the amount of 'corner cutting' by drivers, and
- reduce the amount of scouring in areas of high rainfall, if provided with batter protection for the drainage paths.

An EDD version of *Austroads Guide to Road Design – Part 4A*, Figure 8.2, that can be used at low volume intersections where there are not significant numbers of heavy vehicles, is given in Appendix A.6.

8.2.7 Provision for cyclists at rural free flow left-turn lanes on bicycle routes

Addition

Slip resistant chevrons without RRPMS would help to advise cyclists that a potential hazard is approaching (the added lane, in this case), whilst minimising the hazard from the surface if a cyclist does not use the detour for some reason.

8.3 Urban Left-turn Treatments

8.3.1 Urban Basic Left-turn treatment (BAL)

Addition

For left-turn treatment selection in Queensland, refer to QGTM Part 6.

Where a left-turn is not permitted, a minimum kerb return radius of at least 0.5 m is to be designed. A right angle in the kerb line is generally unacceptable, even in these circumstances, as the arris is prone to damage.

Where a left-turn is permitted, the minimum kerb return radius without a corner cut-off (which interferes with the adjoining property) is equal to the footway width provided. Such an arrangement is appropriate for cars and the occasional single unit truck (such as the garbage truck), provided that there is sufficient pavement width available for the turning path.

This arrangement can be used for the left-turn out of a local street into local and collector roads, especially if one-way conditions apply. However, this layout is generally not acceptable at sub arterial and arterial intersections. At such sites, there may be a need to accommodate heavy vehicle turning movements.

For left-turn movements from the major road to the minor road, it is preferable to provide a widened area using part of a parking lane and providing a parking limit.

8.3.3 Urban Auxiliary Left-turn treatment (AUL) on the major road

Addition

Urban Left-turn treatments for motor vehicles involve a conflict with people cycling straight-on. If the left-turn is designed with an auxiliary lane to the left of a bicycle lane, it can result in extended exposure, increased vehicle speed at the conflict point, expanded pavement where conflict can occur, and rewarding of poor driving practice. These safety risks can be avoided by implementing physically separated cycle tracks at the intersection (refer to Transport and Main Roads Guideline *Selection and Design of Cycle Tracks*).

8.3.6 Provision for cyclists at urban channelised treatments

Addition

Treatment options for left-turn lanes include:

- a crossing treatment close to the island gore, and
- a weave right transition.

A multi-lane left-turn roadway requires a signalised pedestrian crossing. In this case, the associated provision of a bicycle crossing lantern with the pedestrian signals would be preferred over the weave-right transition.

Transport and Main Roads Guideline *Including provisions for bicycles in road pavement rehabilitation and resurfacing projects* provides further guidance on layout considerations.

8.3.7 Left-turn treatments for large vehicles

Addition

Refer to Transport and Main Roads Guideline *Selection and Design of Cycle Tracks* for intersection forms which mitigate the risk associated with conflicts for cyclists and pedestrians in these situations.

10 Signalised Intersections

10.1 Design Process

Addition

At urban signalised intersections, consideration should be given to accommodating cycling movements using protected intersection design (refer to Transport and Main Roads Guideline *Selection and Design of Cycle Tracks*).

10.2 Sight Distance

Addition

If the road alignment does not provide sufficient sight distance and the existing geometry cannot be adjusted, provision of advance warning signs or advance warning signals (e.g. flashing yellow lights) may be considered as a mitigating device.

10.3 Signal Operation Considerations

10.3.1 Traffic operation at an intersection

Addition

Complex intersections, such as fast diamonds, require additional consideration to ensure safe operation is maintained. Additional signal aspect redundancy ensures that drivers can see multiple operational traffic signal aspects fail.

10.4 Intersection Layouts

Addition

The following guidance applies to signalised intersections:

- The layout of the intersection should provide for the optimum location of traffic signal hardware and appropriate clearance to this hardware. Median widths must be large enough to store traffic signal equipment.
- While appropriately balancing the needs of other geometric parameters, the distance that vehicle and pedestrian movements need to travel from the stop line to clear the intersection should be minimised. Longer distances require longer inter-green times to safely allow these movements to clear the intersection and thereby reduce the intersection capacity.
- Where it is desirable to use diamond phasing, appropriate clearance should be provided between right-turning movements (refer to *Austroads Guide to Traffic Management – Part 6*), and
- A late start interval may be used to delay the introduction of a green signal group at a controlled left-turn slip lane where there is a large corner island (instead of increasing the clearance interval for the entire signal group). This allows vehicles to clear the conflict area before the left-turn is introduced (refer to Figure 10.4 below).

Figure 10.4 – Late start for large corner islands

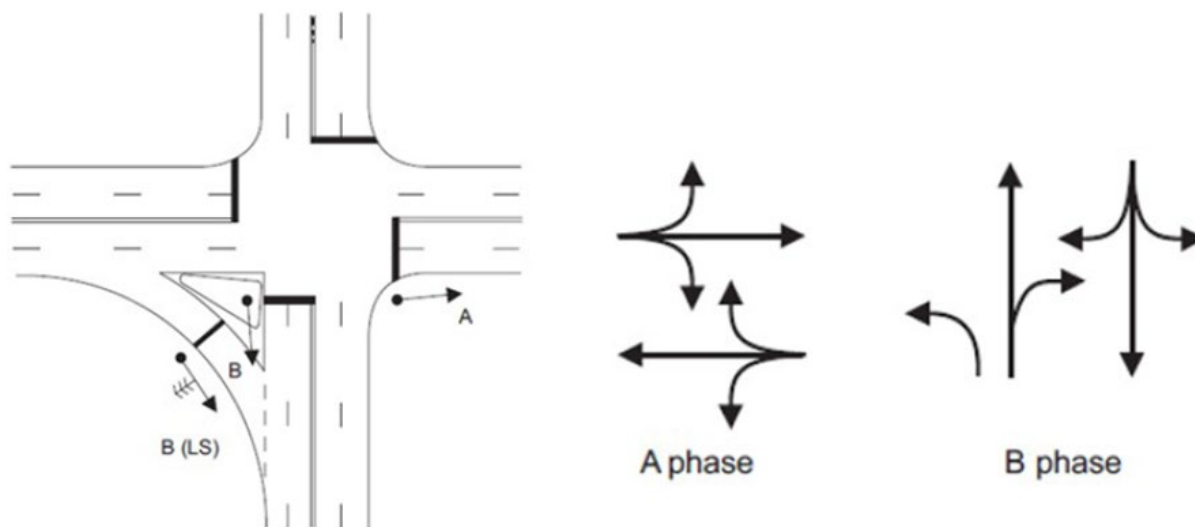

- Medians and islands
 - Refer to Table 10.4 below. The absolute minimum width of raised medians for 2-stage pedestrian mid-block crossings of 2.5 m is needed to store pedestrians, and
 - The use of wide medians reduces intersection capability because of increased clearance times for vehicle and pedestrian movements. For intersections with wide medians, consider staging pedestrian movements. Also, wide medians may cause the problem of interlocking opposing right-turn vehicles and therefore should be avoided.

Table 10.4 – Minimum widths of raised medians

Situation	Desirable	Absolute (m)
No posts	1.2	0.9
Post with single 200 mm lanterns	2.4	1.2
Post with dual 200 mm lanterns	2.4	1.5
2-stage mid-block pedestrian crossing	4.0	2.5

10.4.2 Service road treatments

Addition

As an alternative to the treatments shown in Figure 10.3 of *Austroads Guide to Road Design – Part 4A*, if space is available, the service road can be ‘bulbed’ to intersect the crossroad at a distance from the intersection sufficient to form a separate intersection. This distance should be longer than the expected queue at the intersection or a minimum of 20 m (allows a semi-trailer to perform a U-turn between inside lanes).

10.6 Cyclists Facilities

10.6.1 On-road bicycle lanes

General

Addition

Where right-turn bicycle lanes are provided, it is assumed that alternative paths through the intersection will be provided for younger and less experienced cyclists. It is considered that bicycle hook-turns and/or bicycle crossing signals would cater for less experienced cyclists.

Bicycle lanes on signalised intersection approaches

Addition

Where a bicycle lane is to be retrofitted through an existing signalised intersection, the position of existing detector loops is to be established. Reinstallation of the loops may be required, depending on the proposed lateral shift of traffic lanes induced by the bicycle lane.

Head start and bicycle storage areas

Addition

Use of head start and bicycle storage areas should be considered when upgrading or retrofitting signalised intersections. Bicycle storage areas should be considered where there is a signal-controlled left-turn lane coupled with high volumes of left-turning vehicles, buses or heavy vehicles.

On particularly long intersections (e.g. single point diamond), a check of inter-green time should be made to ensure an on-road cyclist can clear the intersection.

Notes added to Figure 10 9 of *Austrroads Guide to Road Design – Part 4A*:

- LHS = 3 m minimum, 4 m to 5 m desirable
- Treatment (b): The left-turn phase must occur at the same times as the through traffic phase to avoid conflicts between left-turning vehicles and cyclists stopped in the storage box, and

- Treatment (d): Hook-turns can be completed by cyclists at any intersection, unless otherwise signed. The painted hook-turn storage box is intended to make cyclists aware of the alternative right-turn method available and indicate the appropriate location to wait. Installation of a painted hook-turn storage box is recommended where cyclists would need to cross 2 or more through traffic lanes to access a right-turn lane. Installation of a bicycle detection loop under the painted hook-turn storage area should be considered if the side street signal phase is only activated on demand, and it is estimated that a cyclist could have a lengthy wait before a vehicle would arrive to activate the side street phase. For hook-turns to work effectively, the traffic signal phase should progress clockwise around the intersection.

Bicycle paths

There is no equivalent Section 10.6 in Austroads *Guide to Road Design – Part 4A*.

New

Where a bicycle path forms one of the arms of a signalised junction, loop detectors, provided sufficiently in advance, can trigger the appropriate phase at the signals with minimal delay to a cyclist using the path.

10.7 Pedestrian Treatments

There is no equivalent Section 10.7 in Austroads *Guide to Road Design – Part 4A*.

New

Pedestrian crossings on all intersection legs

The department's default position is that pedestrian crossings are to be provided on all approaches at signalised intersections. Where turning vehicles can conflict with a pedestrian movement, pedestrian protection shall be provided by delaying the start of vehicle movements. The length of the delayed start will depend on the type of pedestrians using the crossing, the flow of pedestrians and the flow of conflicting vehicles, however, a minimum of 4 seconds is required to allow pedestrians to establish themselves on the crossing before vehicle movements begin.

Intersection of pedestrian crossings

Where 2 pedestrian crossings meet, the intersection point of the outside edges should be no more than 1 m from the face of the kerb. This is to minimise conflicts by pedestrians in separate phases and to deter pedestrians from waiting on the road pavement (refer to Figure 10.7(a)).

Figure 10.7(a) – Intersection of pedestrian crossings

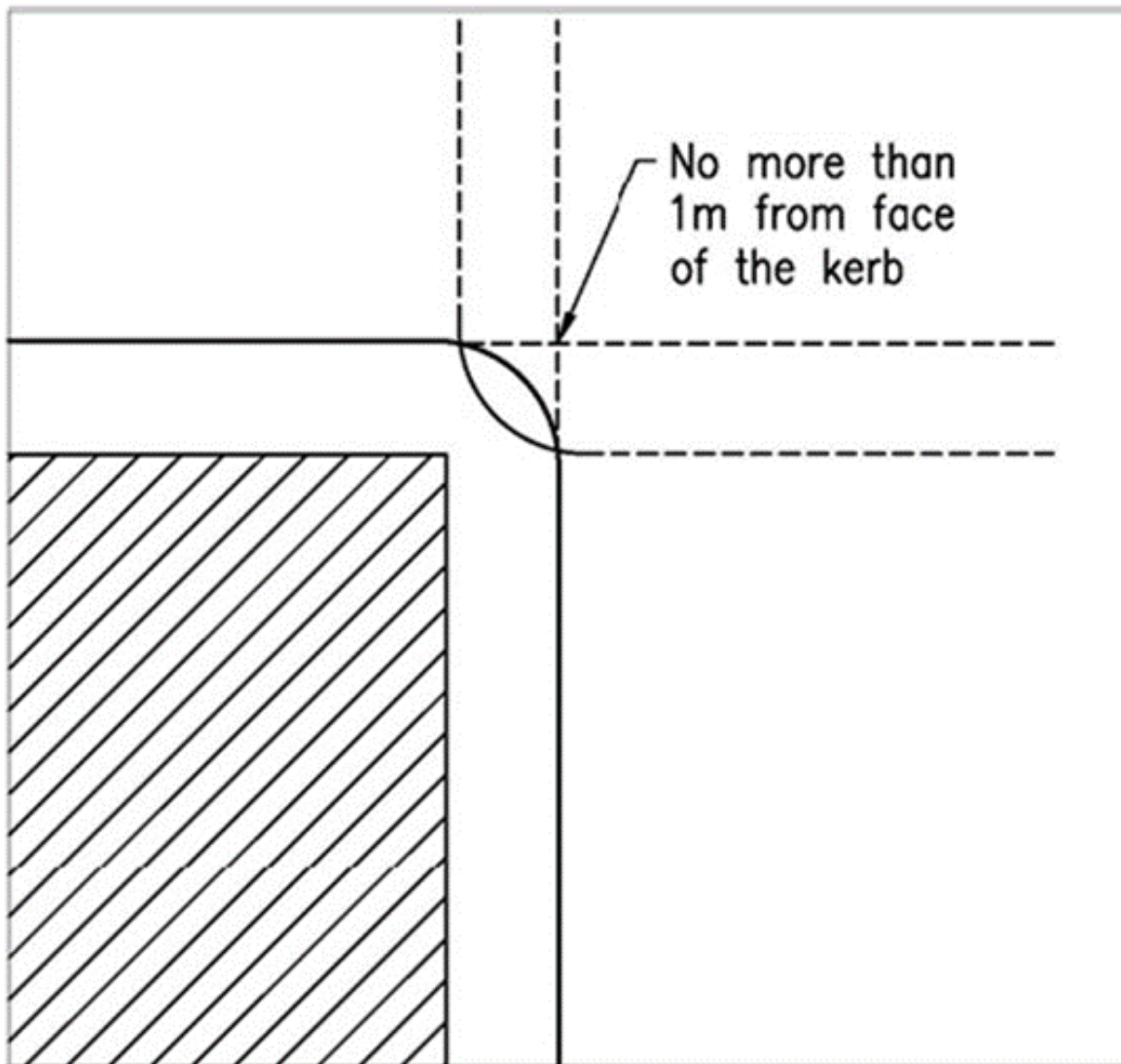

Median islands

When a pedestrian crossing is provided, the median should preferably terminate at the crossing unless a gap in the median as wide as the crossing is provided and the median continued for at least 2 m beyond the crossing (refer to Figure 10.7(b) below).

Figure 10.7(b) - Treatment of pedestrian crossings

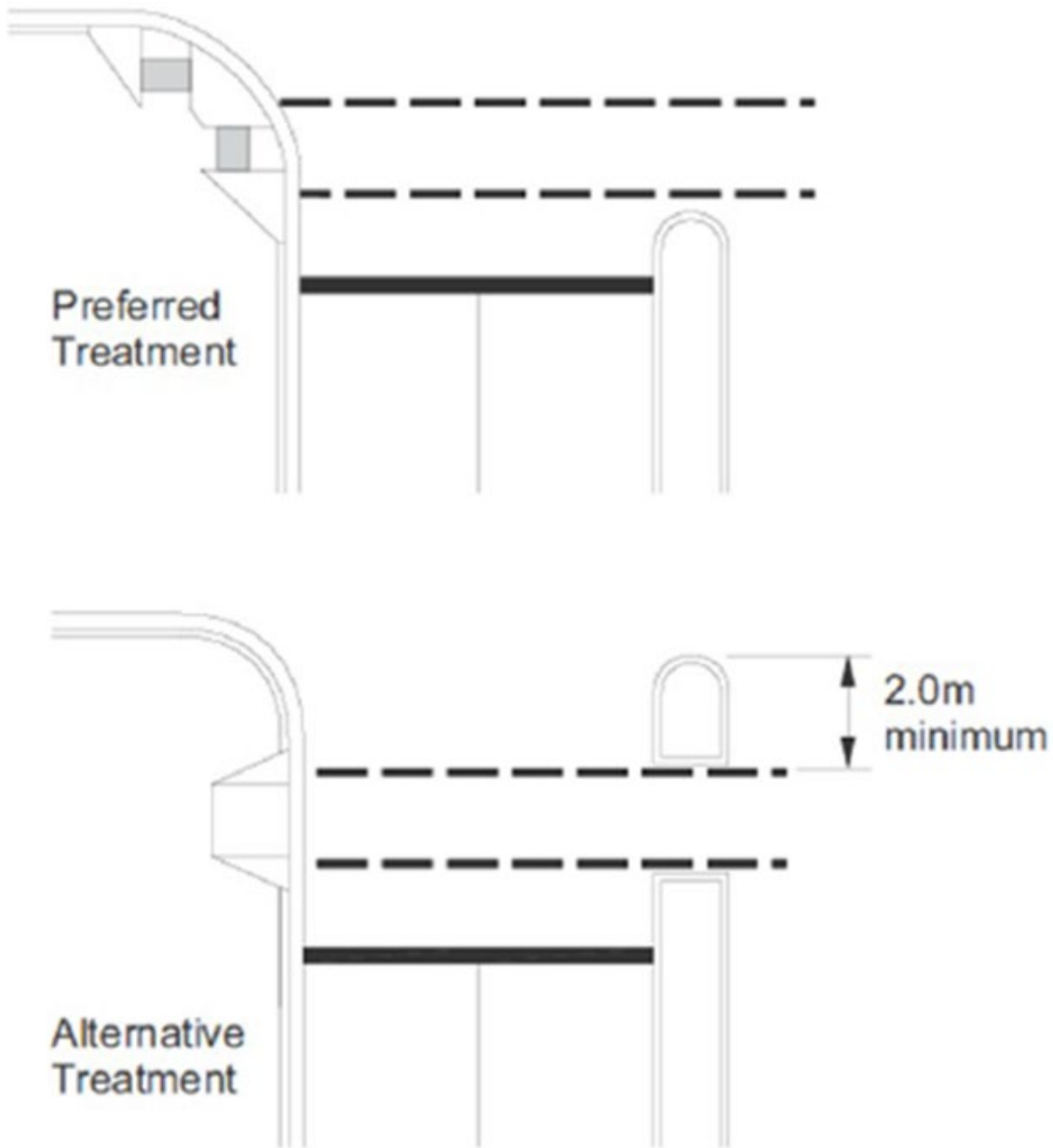

References

Transport and Main Roads publication references refer to the latest published document on the department's [Technical publications website](#).

Addition

Austroads. *Guide to Road Design Part 3, Geometric Design*. Sydney, NSW

Austroads. *Guide to Road Design Part 4, Intersections and Crossings – General*. Sydney, NSW

Austroads. *Guide to Road Safety Part 6, Managing Road Safety Audit*, Austroads. Sydney, NSW

Austroads. *Guide to Traffic Management Part 3, Transport Study and Analysis Methods*. Sydney, NSW

Austroads. *Guide to Traffic Management Part 6, Intersections, Interchanges and Crossings Management*. Sydney, NSW

Austroads. *Cycling Aspects of Austroads Guides, AP-G88-17*. Sydney, NSW

Austroads. *Methods for Reducing Speeds on Rural Roads – Compendium of Good Practice, AP-R449-14*. Sydney, NSW

Department of Transport and Main Roads. *Cycling Infrastructure Policy*. Brisbane: Queensland Government

Department of Transport and Main Roads. *Guideline Bicycle Rider and Pedestrian Underpasses*. Brisbane: Queensland Government

Department of Transport and Main Roads. [Guidelines for Cyclists and Pedestrians](#)

Department of Transport and Main Roads. *Guideline Raised Priority Crossings for Pedestrian and Cycle Paths*. Brisbane: Queensland Government

Department of Transport and Main Roads. *Road Planning and Design Manual 2nd Edition (RPDM)*. Brisbane: Queensland Government

Department of Transport and Main Roads. *Guideline Selection and Design of Cycle Tracks*. Brisbane: Queensland Government

Department of Transport and Main Roads. *Queensland Manual of Uniform Traffic Control Devices (Queensland MUTCD)*. Brisbane: Queensland Government

Department of Transport and Main Roads. *Traffic Control Signs*. Brisbane: Queensland Government

Department of Transport and Main Roads. *Traffic and Road Use Management Manual (TRUM)*, Brisbane, QLD

Standards Australia. *AS/NZS 2890.1 Parking Facilities – Part 1: Off-street car parking*.
Australian Government

Appendix A – Extended Design Domain (EDD) and Design Exception (DE) and potential mitigation strategies for intersections

Addition

The title of Appendix A of Austroads *Guide to Road Design – Part 4A* has been changed to reflect that this Appendix deals with both EDD and DE and potential mitigation strategies for intersections.

A.1 General

Addition

This section also provides Design Exception (DE) values and potential mitigation strategies for intersections. These are values outside of the Extended Design Domain (EDD) that have been developed through examining current practice in Queensland, other Australian states and other countries.

A.2 EDD for sight distance at intersections

A.2.2 Base and check cases

Difference

In Table A1 of Austroads *Guide to Road Design – Part 4A*, the case descriptions for 'Truck-day' and for 'Truck-night' are replaced with the following:

Case type	Case code	Case description
Base case (mandatory application)	Truck-day	Truck driver travelling at the 85th percentile truck speed in daylight hours
Check case (ensure that adequate capability exists under these conditions, as relevant)	Truck-night	Truck driver travelling at the 85th percentile truck speed on an unlit roadway at night

A.2.5 EDD Safe Intersection Sight Distance (SISD)

Difference

Delete the word 'only' in the 2nd sentence of the 3rd dot point, *Longitudinal Deceleration*, to read 'Dry weather stopping is not used under SISD...'

A.3 EDD for sight distances at domestic accesses

A.3.1 Application of EDD for sight distances at domestic accesses

The last paragraph is to be deleted and replaced with 'Application of EDD sight distance at domestic accesses should only be used if there is no sight distance related crash history.'

A.5.7 EDD for right-turn treatments on existing urban roads (S lanes)

The Engineering and Technology Road Design Unit must be consulted if the use of this treatment is being considered.

A.5.8 Turning lanes

There is no equivalent Section A.5.7 in *Austroads Guide to Road Design – Part 4A*.

New

Width of turn lanes at intersections is predicated on the turning path of the design vehicle and clearances to adjacent kerbs. It is usual to provide sufficient width to pass a stopped vehicle (combination of lane and shoulder width) and this is addressed in *Austroads Guide to Road Design – Part 4A*. The minimum width is set at 5 m but is not mandatory; the ability to pass a stopped vehicle being allowed to be achieved by using space beyond the kerb line (surface of islands). In such cases, the kerbs must be mountable or semi-mountable, and furniture (signals, signs) must be kept clear of the area potentially used by passing vehicles.

The width of a right-turn lane in the median of an intersection is desirably 3.5 m but widths of 3 m have often been used. The minimum width that could be tolerated is 2.5 m, which will accommodate a passenger car. This should only be used if the adjacent lane is 3.5 m wide (this would be a design exception).

Mitigation includes:

- Ensuring the adjacent travel lane is at least 3.5 m, and
- Ensuring the adjacent median can tolerate incursion by the wheels of a vehicle, i.e. sufficient clearance to any road furniture and sufficient space for a pedestrian to be shielded. Preferably, the operation of the intersection should be such that pedestrians do not need to be stored on the median during the crossing manoeuvre.

A.5.9 Private accesses

There is no equivalent Section A.5.8 in *Austroads Guide to Road Design – Part 4A*.

New

Private property access on rural roads can become hazardous with reasonably high traffic volumes combined with high-speed. Drivers waiting to turn right from the major road are susceptible to rear-end collisions. In many cases, it is not feasible to provide separate service roads or to provide a protected right-turn lane for such accesses.

The following design exception solution may be considered after all other traditional design solutions have been considered and found to be unsatisfactory in context. Provide a widened shoulder (3 m with 1 in 25 tapers from the usual shoulder edge) opposite the access to allow the turning vehicle to wait until traffic is clear in both directions and then undertake the right-hand turn (sometimes referred to as a hook-turn) (refer to Figure A.5.8). This solution must be developed in consultation with the property owners. It is important that the size of the widening does not convey a message that it is an overtaking lane.

Left-hand turns should be provided with shoulder widening to allow the vehicle turning left to move clear of the through-lane edge. 1 in 10 tapers to achieve a 3 m shoulder adjacent to the access is required.

Property accesses should desirably be removed from either side of the crest of sub-standard vertical curves, i.e. just over the crest in either direction. In some cases, an access precisely on the crest with equal visibility in both directions will be acceptable (appropriate earthworks to provide suitable visibility of the access will be required). Allowing accesses without at least EDD sight distance is undesirable as there is little in the way of mitigation that can be done. Even if the primary user is familiar with the environment, that user will not be able to detect an oncoming vehicle and, to the oncoming vehicle, an entering or exiting vehicle will be a complete surprise with little scope for taking avoiding action. Consultation with the property owner should be undertaken with the objective to relocate the access to a safer location if possible.

Figure A.5.8 – Example of private entrance widening - Hook right-turns

WIDENING OPPOSITE PRIVATE ENTRANCE

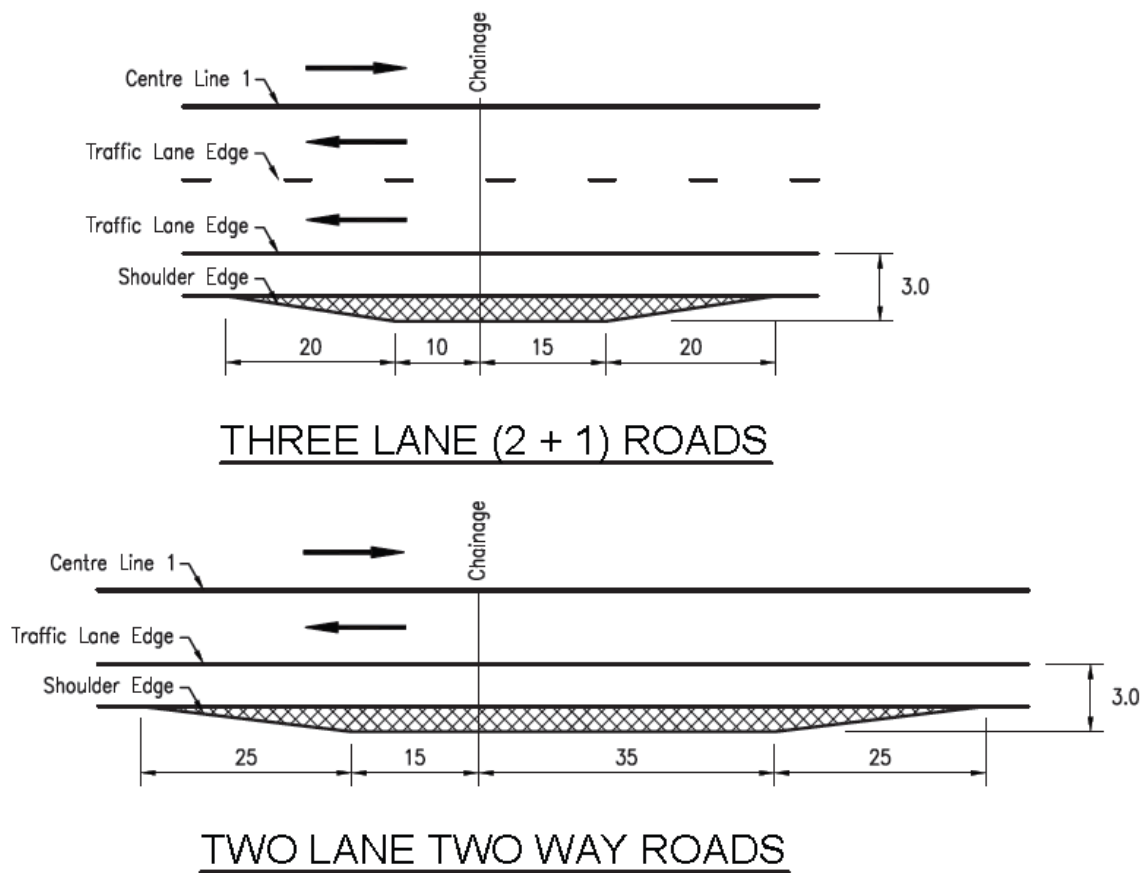

A.6 EDD treatment of a constrained left-turn radius

Addition

The following Figures A.6(a) and A.6(b) present EDD layouts for BAL turn treatment subject to constraints. These treatments allow for heavy vehicle encroachment onto adjacent lanes when making left-turns into or out of the minor road.

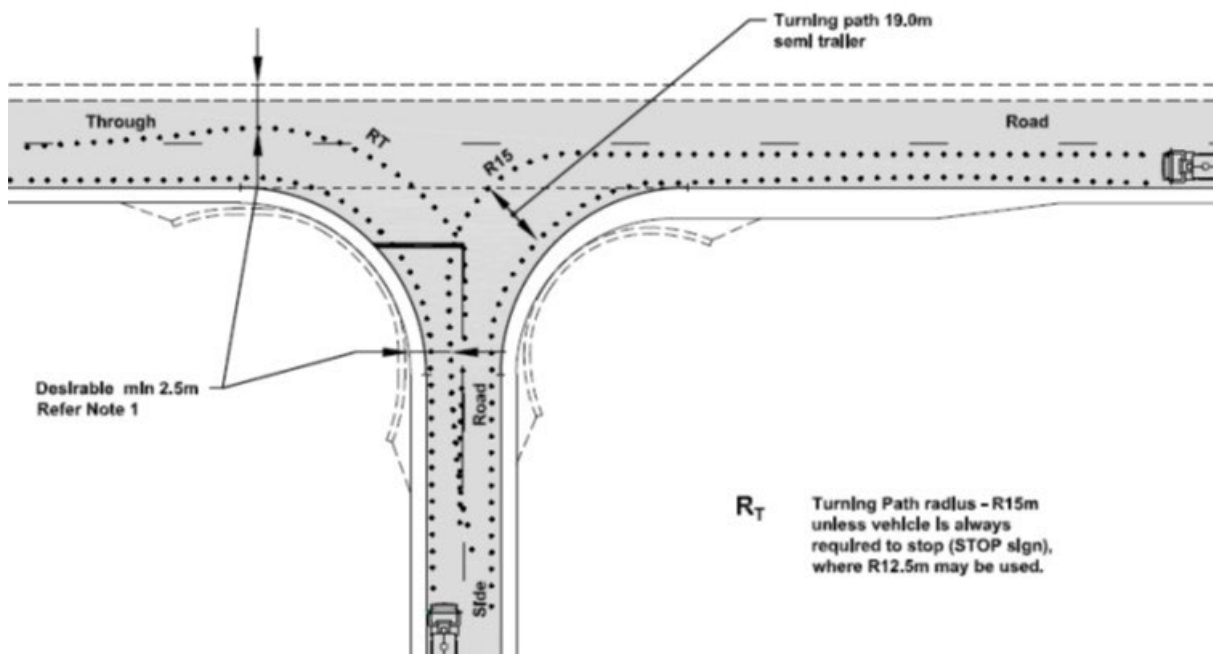
Figure A.6(b) – Basic Left-turn treatment (BAL) on a rural road, side road < 50vpd AADT**Notes:**

1. Minimum distance between outer edge of the swept path and the edge of formation is to be 2.5 m to allow for situations where a vehicle arrives during the large vehicle turning movement and attempts to continue to pass.
2. Layout not to be used when:
 - Annual Average Daily Traffic (AADT) of the side road is more than 50 vehicles / day
 - AADT of the major road is more than 500 vehicles / day
 - there are significant volumes of articulated vehicles (more than about one turning articulated vehicle per day), and
 - it is associated with other minimum criteria (e.g. sight distance restricts or tight horizontal curves).
3. This Figure shows EDD Swept Paths only. All other dimensions are shown in Figure 8.2 of Austroads *Guide to Road Design – Part 4A*.

A.11 EDD warrants for intersection turn treatments

There is no equivalent Section A.11 in Austroads *Guide to Road Design – Part 4A*.

New

The EDD warrants for determining the preferred intersection turn treatment (refer to Figure A.11(a)) represent alternative design criteria for application at sites subject to site constraints or where the costs of the intersection upgrade are considered impractical. These criteria can therefore be considered for application at brownfield sites where construction costs are higher due to the ad-hoc nature of the works and the management of traffic.

These warrants apply to 2L2W and can be applied for 4L2W and 6L2W roads. MNR intersection types, as discussed in Section 3.2.2 of Austroads *Guide to Traffic Management – Part 6*, may be retained at these intersections subject to a Design Exception evaluation. SR / SL turn treatments are described in Section 4.3 of this supplement.

The EDD warrants should be applied to NDD turn treatment layouts. Only in extreme constrained situations should the EDD warrants be combined with the EDD turn treatment layouts. The combination of the 2 EDD elements should be treated as a design exception.

The warrants in Figure A.11(a) are based on achieving a specific level of safety performance. An evaluation of the operational performance of the intersection should also be undertaken. If the operational performance indicates a higher level treatment is needed, then it should be adopted in lieu of the warrants in Figure A.11(a).

Further commentary on the methodology behind these warrants is provided in Commentary 10.

Figure A.11(a) - Warrants - Major road turn treatments - Extended Design Domain

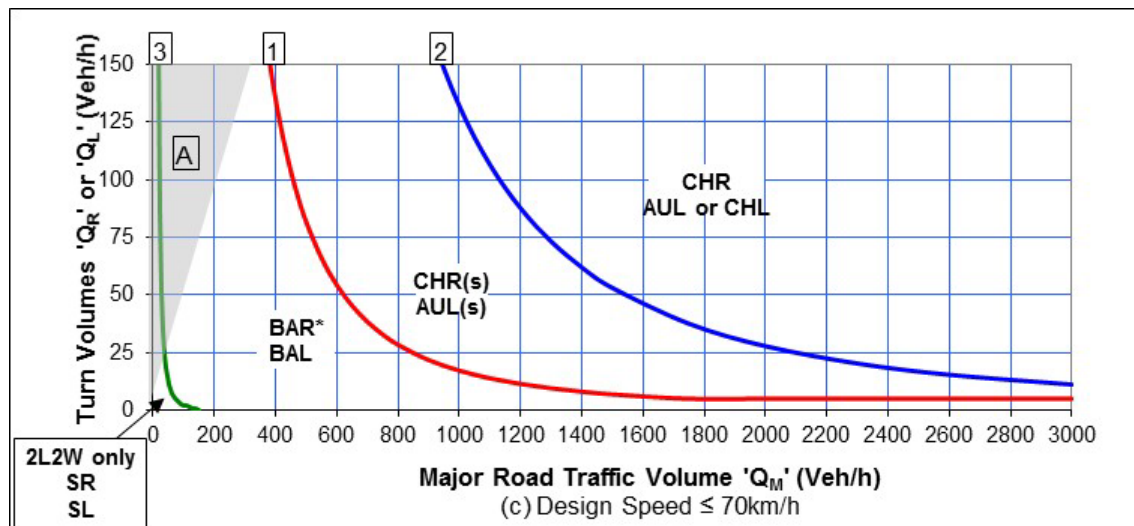
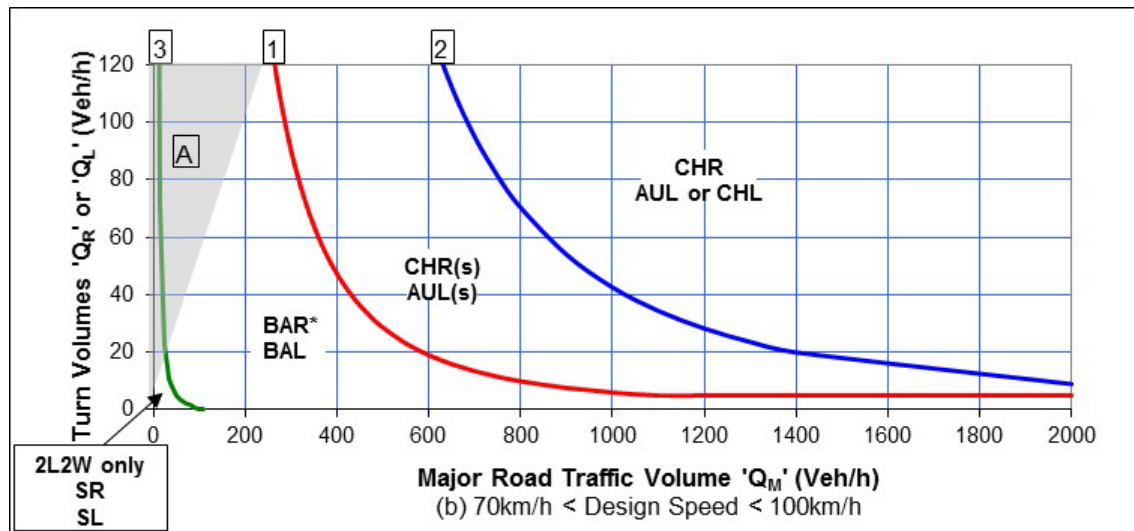
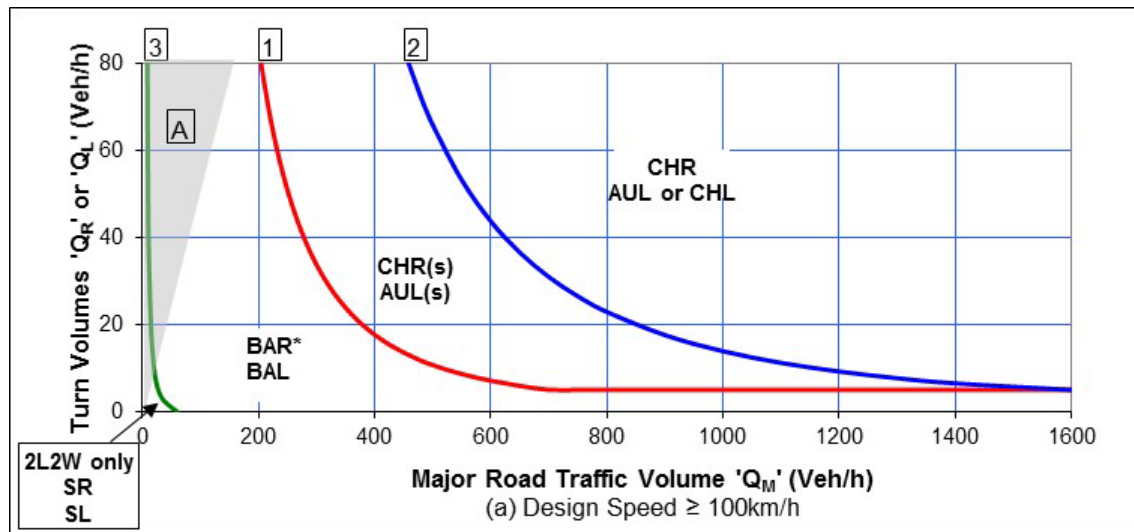

Note:

* The minimum right-turn treatment for multi-lane roads is a CHR(S)

Figures A.11(a) - (d), (e) and (f) respectively expand the view of the bottom left corner of diagrams (a), (b) and (c)

Figure A.11(a) (continued)

(expanded view of the bottom left corner of the warrants diagrams at A.11(a) - (a), (b) and (c))

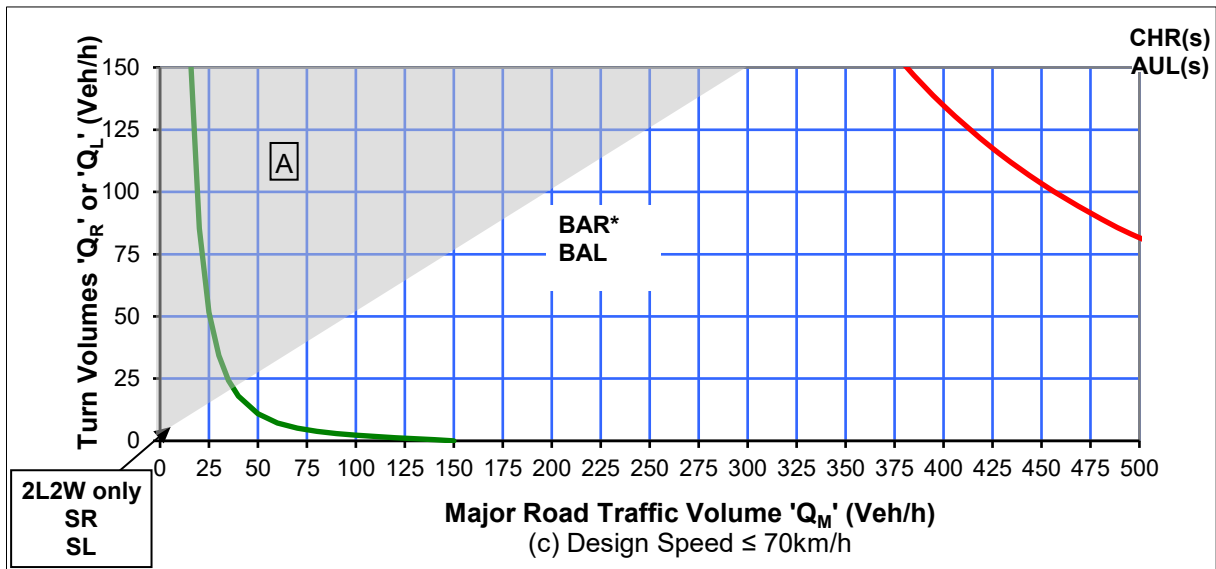
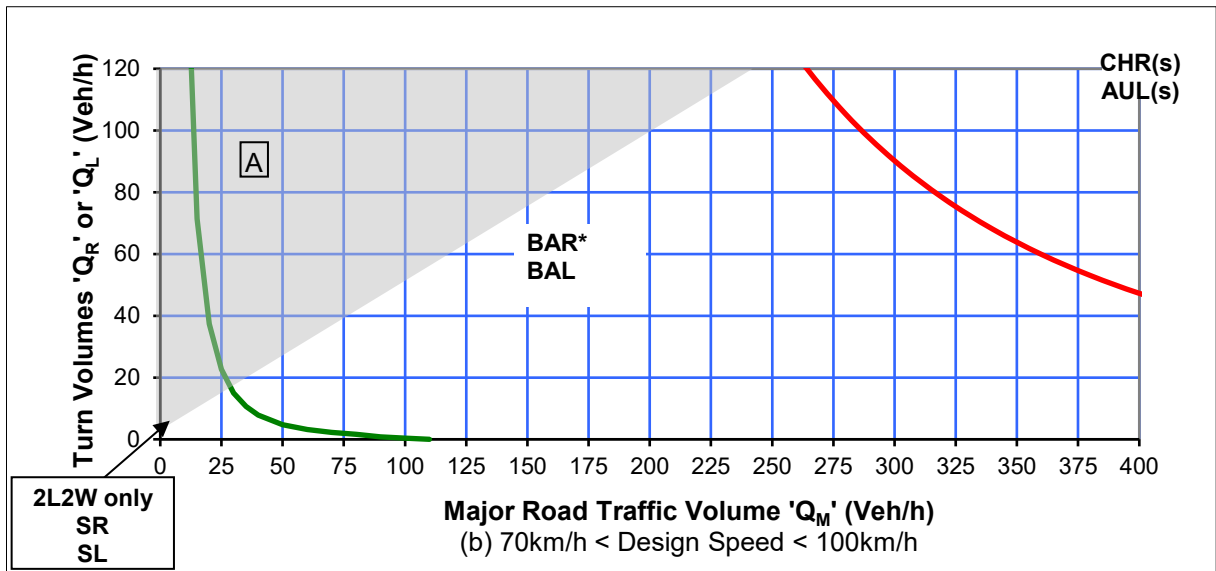
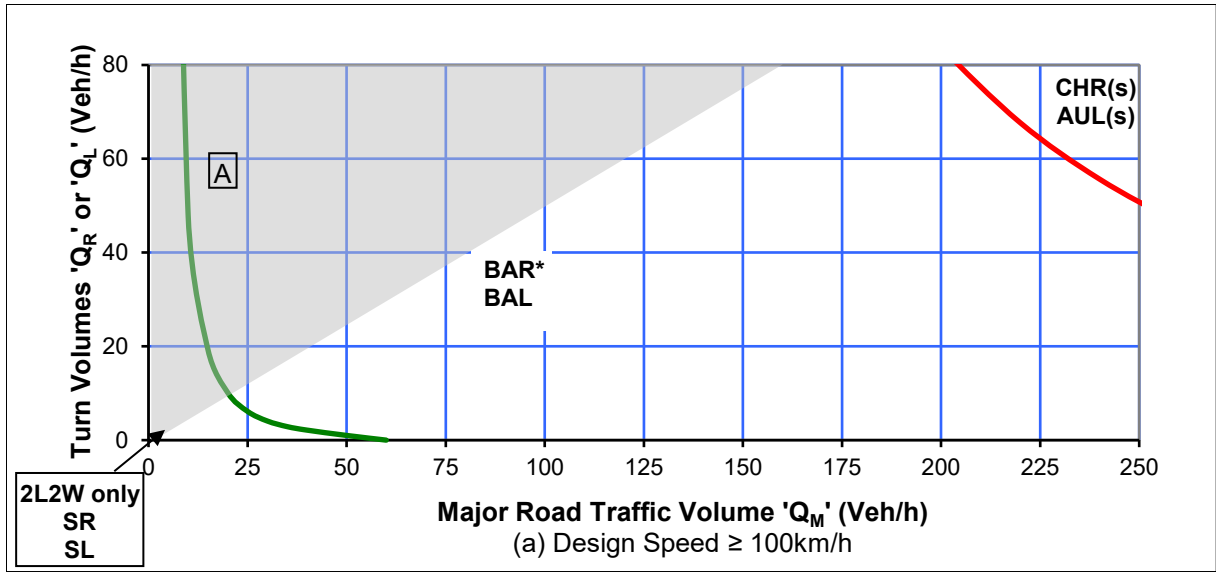

Note:

* The minimum right-turn treatment for multi-lane roads is a CHR(S)

The following notes apply to the warrants in Figure A.11(a)

1. Curve 1 – For 2L2W roads, Curve 1 represents the boundary between a BAR and a CHR(S) turn treatment and between a BAL and an AUL(S) turn treatment. For 4 / 6L2W roads, Curve 1 represents the boundary between a BAL and an AUL(S) turn treatment only. The minimum right-turn treatment is a CHR(S) on 4 / 6L2W roads.
2. Curve 2 represents the boundary between a CHR(S) and a CHR turn treatment and between an AUL(S) and an AUL / CHL turn treatment. The choice of CHL over an AUL will depend on factors such as the need to change the give way rule in favour of other manoeuvres at the intersection and the need to define more appropriately the driving path by reducing the area of bitumen surfacing.
3. Curve 3 represents the boundary between a simple intersection treatment and a BAR / BAL turn treatment for 2L2W roads only.
4. The warrants apply to turning movements from the major road only (the road with priority). For turns from the minor road, turn treatments are determined through an operational performance evaluation applying gap acceptance analysis and an evaluation of acceptable delays and queues.
5. Q_M
 - a) For 2L2W roads, Figure A.11(b) is to be used to calculate the value of the major road traffic volume parameter (Q_M) and is the total through traffic flow in both directions ($Q_{T1} + Q_{T2}$), and
 - b) For 4 / 6L2W roads, the major road traffic volume parameter (Q_M) for right-turns uses the full opposing flow Q_{T2} and only the traffic flow in the nearest lane of the following flow Q_{T1} as per Figure A.11(b). For left-turns, the major road traffic volume parameter (Q_M) uses only the traffic flow in the leftmost through-lane of the following flow Q_{T2} .

Figure A.11(b) – Calculation of the major road traffic volume parameter ‘ Q_M ’

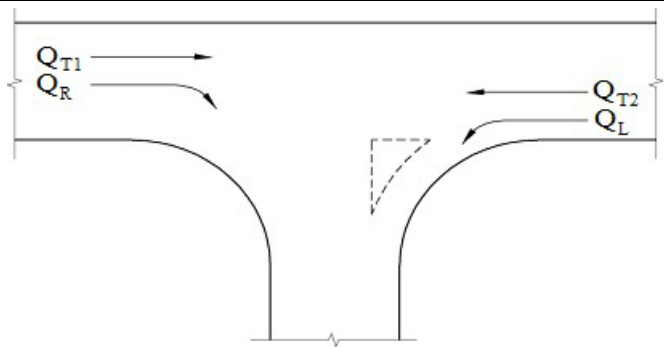

Road Type	Turn Type	Splitter Island	Q_M (veh/h)
2 Lane 2 Way	Right	No	$= Q_{T1} + Q_{T2} + Q_L$
		Yes	$= Q_{T1} + Q_{T2}$
	Left	Yes/No	$= Q_{T2}$
4 Lane 2 Way	Right	No	$= 50\% \times Q_{T1} + Q_{T2} + Q_L$
		Yes	$= 50\% \times Q_{T1} + Q_{T2}$
	Left	Yes/No	$= 50\% \times Q_{T2}$
6 Lane 2 Way	Right	No	$= 33\% \times Q_{T1} + Q_{T2} + Q_L$
		Yes	$= 33\% \times Q_{T1} + Q_{T2}$
	Left	Yes/No	$= 33\% \times Q_{T2}$

6. Traffic flows applicable to the warrants are peak hour flows, with each vehicle counted as one unit (i.e. do not use equivalent passenger car units [pcus]). Where peak hour volumes or peak hour percentages are not available, assume that the design peak hour volume equals 15% of the AADT for 500 hours each year, use 5% of the AADT for the remainder of the year.
7. If more than 50% of the traffic approaching on a major road leg turns left or right, consideration needs to be given to possible realignment of the intersection to suit the major traffic movement. The shaded area (A) denotes the traffic flow combinations where this occurs. However, route continuity issues must also be considered (for example, realigning a highway to suit the major traffic movement into and out of a side road would be unlikely to meet driver expectation).
8. If a turn is associated with other geometric minima, consideration should be given to the adoption of a turn treatment of a higher order than that indicated by the warrants, and
9. At higher traffic volumes, consideration should also be given to the operational performance of the intersection which may require a higher level turn treatment, or alternative intersection control, than required by these warrants based on crash analysis.

A.12 Island size

There is no equivalent Section A.12 in Austroads *Guide to Road Design – Part 4A*.

New

Section 6.1.2 of Austroads *Guide to Road Design – Part 4A* provides guidance on the minimum island sizes that should be adopted. If a smaller island than that shown in Table 6.3 and Table 6.4 of Austroads *Guide to Road Design – Part 4A*, is to be installed, it is a design exception and the following issues must be considered in justifying its acceptance.

Considerations for design exceptions

In assessing the size of a raised island at an intersection, the fundamental consideration is that of the function of the particular island and how it satisfies that requirement. The usual functions include:

- separation of traffic streams (same or opposite direction)
- prevention of use of certain areas by traffic
- space for the erection of signs, traffic signals and lighting poles, and
- space for pedestrian refuge which considers demand and caters for disability access (mobility devices).

An island may fulfil any combination of these functions but will almost always need to cover the 1st 2 dot points above. Signs, signals and poles may or may not be required (lighting poles should be avoided as there will usually be an alternative location that can provide a suitable solution). Pedestrians are not always present and sometimes only in small numbers.

If the space available for the island is too small, it will become more of a hazard in itself and a painted island will suffice.

Where signs are required in the island, there must be sufficient space to accommodate the full width of the sign plus clearance to the edges of the sign as defined in the Queensland MUTCD. In rural areas, the minimum clearance to the edge of the sign is 600 mm from the road edge. In urban areas, the minimum is 300 mm from the face of the kerb but 500 mm from the face of a mountable or semi-mountable kerb. Hence, the width of the island required will be the width of the sign plus the required clearance on both sides.

The length of the island may need to be shorter than the dimensions provided in Table 6.3 of *Austroads Guide to Road Design – Part 4A*. A sensible minimum, given severe site constraints, could be taken as 2 times the width determined from the functional requirements with a minimum of 3 m. Such an island would be very small in area and would need significant treatment to ensure sufficient conspicuity.

A.12.1 Mitigation

There is no equivalent Section A.12.1 in *Austroads Guide to Road Design – Part 4A*.

New

The major issue with a small island will be its conspicuity. Additional measures to make the island conspicuous will be required. This could include:

- painting the island and kerbs in chevron style with high reflectivity paint
- using wider lead-in lane lines and raised pavement markers, and
- lighting will be essential.

Appendix B – Truck Stability at Intersections

B.2 Lateral friction force on vehicles

Difference

Figure B 1 of Austroads *Guide to Road Design – Part 4A* is accepted for use up to and including speeds of 50 km/h. Transport and Main Roads is aware of additional research work which suggests alternative Lateral Friction Factors for trucks at speeds above 50 km/h. In this guide, speeds above 50 km/h are not generally considered appropriate for the truck design speed for turning movements. Where designs are based on truck turning speeds greater than 50 km/h, specialist input should be sought and reference should be made to RPDM Volume 3, Part 3.

Appendix D – Basic Left-Turn (BAL) Layouts at Rural Intersections

There is no equivalent Appendix D in Austroads *Guide to Road Design – Part 4A*.

New

This appendix provides set-out details to cater for various design vehicles at rural BAL turn treatments.

The below figures are indicative and do not preclude the need to provide shoulder widening as per Figure 8.2 of Austroads *Guide to Road Design – Part 4A*.

Figure D(a) – Details of type 'BAL' layout for rural sites to suit B-double operation

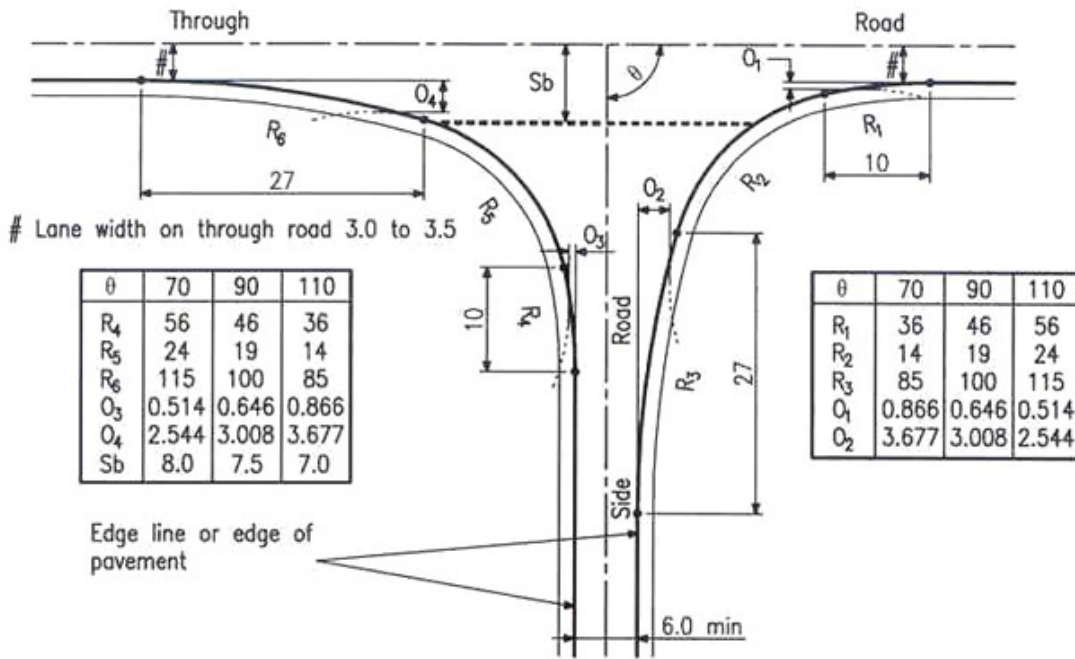

Setting Out Details

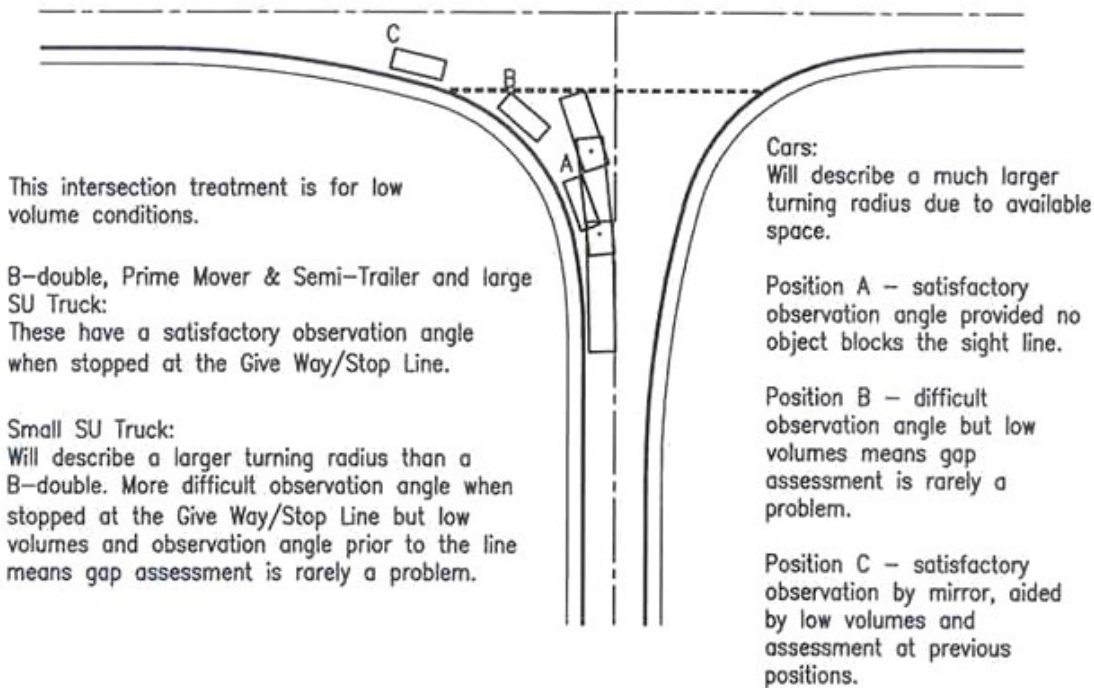

Observation Angle Assumptions

Figure D(b) – Details of type 'BAL' layout for rural sites to suit type 1 (double) road train operation

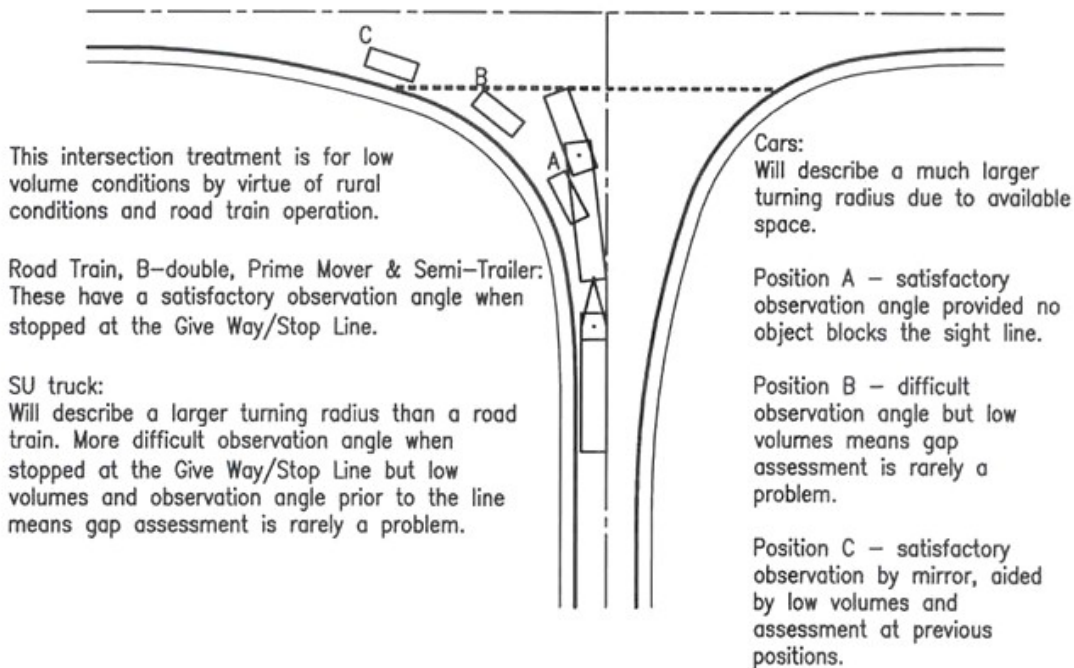
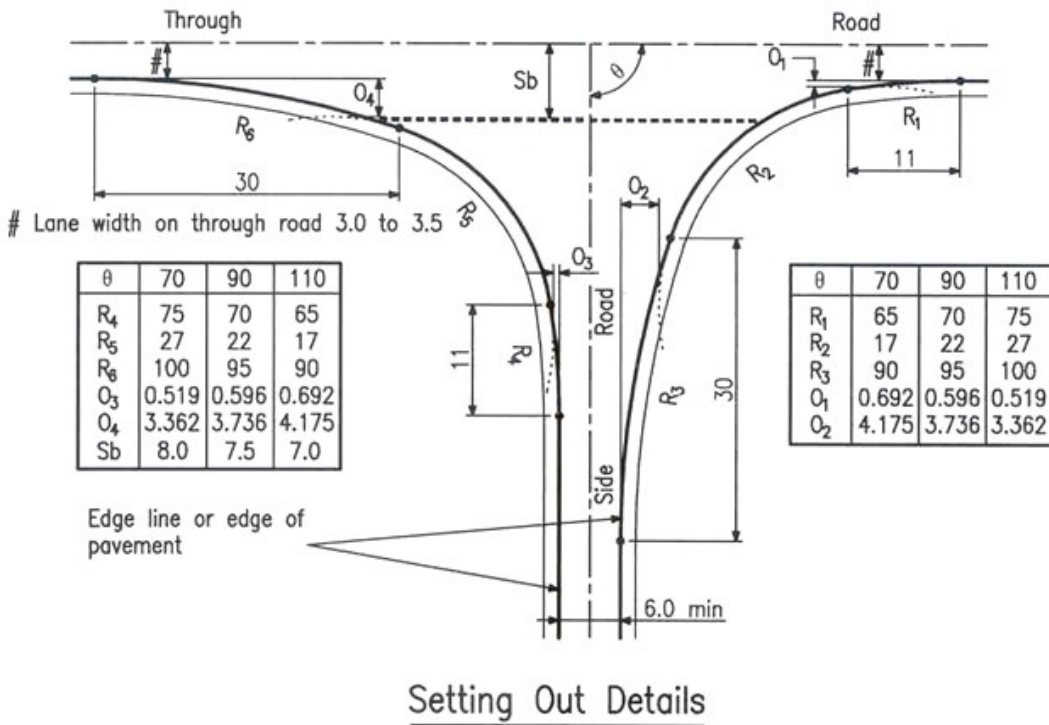
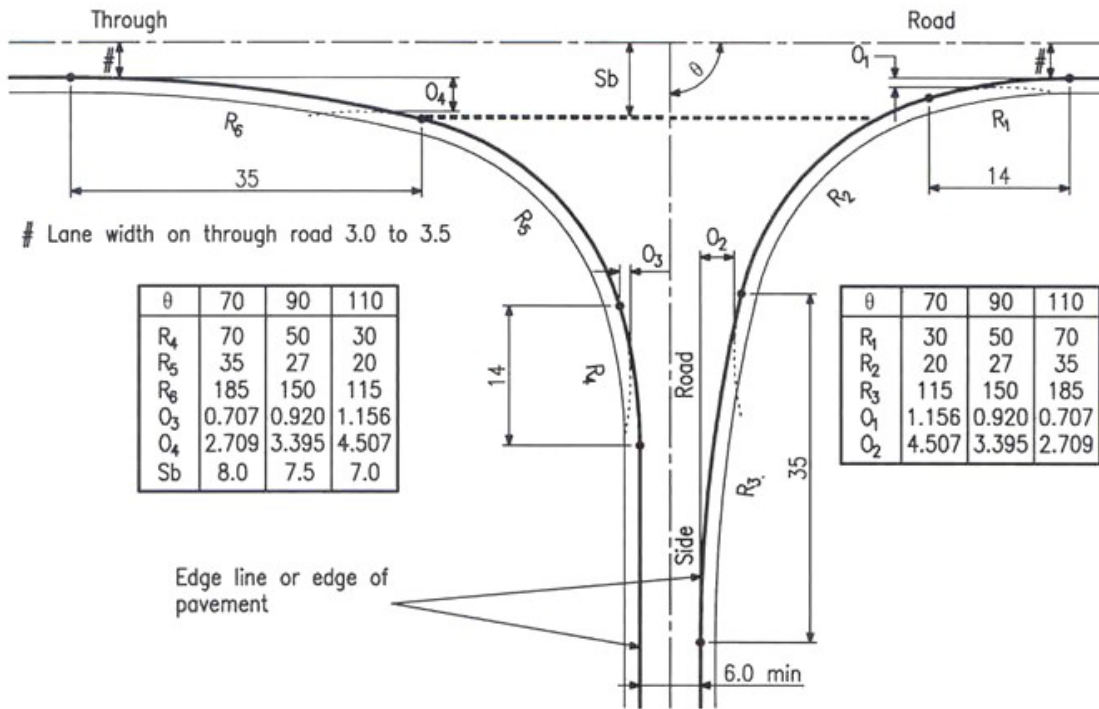
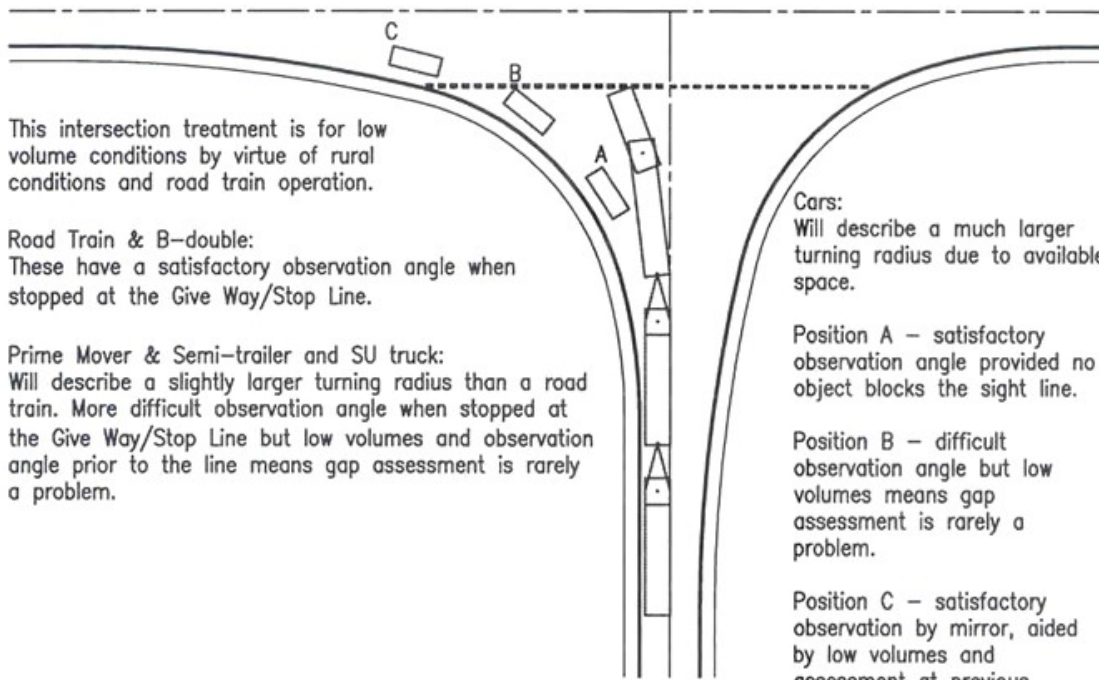

Figure D(c) – Details of type 'BAL' layout for rural sites to suit type 2 (triple) road train operation



Setting Out Details



Observation Angle Assumptions

Commentary 6

Difference

Auxiliary Right-turn Lane (AUR) treatments are not to be constructed at new intersections, and existing AURs are to be replaced with at least a CHR(S).

Commentary 10

There is no equivalent Commentary 10 in Austroads *Guide to Road Design – Part 4A*.

New

Austroads *Guide to Traffic Management – Part 6* details NDD warrants for selection of intersection turn treatments at unsignalised intersections. Appendix A.11 provides details the respective EDD warrants. Both of these sets of warrants are based on the mathematical relationships described in this Commentary.

In highly constrained circumstances, the mathematical approach in this section may be used to undertake a more detailed calculation based on site-specific factors, including the site-specific construction cost estimate for each level of turn treatment and the historical crash rate. This resultant BCR assessment can then be used to evaluate the possible design exception.

The safety benefits, determined from the reduction in estimated accident costs, are estimated for using a higher order left or right-turn treatment as calculated in Equation 4A-6.1 below:

$$C_{RM} = 2.75 \times 10^{-12} \times C_A \times T_{DL} \times Q_i^{0.406} \times Q_M^{0.912} \times S_{MT}^{2.94} \times (e^{T_{TM}} - e^{T_{TA}})$$

Where:

- C_{RM} = safety benefit of using the higher order turn treatment (\$)
- C_A = average cost of a Rear-End-Major vehicle accident = \$38,974 from Arndt (2004)
- T_{DL} = design life (years)
- $Q_i Q_i$ = turning traffic flow from the major leg (veh/h) (Q_R or Q_L as per Figure A.11)
- Q_M = traffic flow (veh/h) on the major legs according to Figure A.11
- S_{MT} = 85th percentile through major road speed (km/h)
- T_{TM} = type of lower-order turn treatment (values given below)
- T_{TA} = type of higher-order turn treatment (values given below)
- MNR = 4.59, BAR=3.83, CHR(S) & CHR=0.00, BAL=0.666, AUL(S) & AUL=0.0493

Example Calculation

The safety benefit of providing a CHR turn treatment in lieu of an existing BAR turn treatment for the following conditions:

Design life $'T_{DL}' = 10$ years

Design right-turn traffic flow $'Q_R' = 60$ veh/h

No splitter island opposite the right-turn

Design approaching through traffic flow $'Q_{T1}' = 190$ veh/h

Design opposing through traffic flow $'Q_{T2}' = 200$ veh/h

Design opposing left-turn traffic flow $'Q_L' = 50$ veh/h

85th percentile through speed $'S_{MT}' = 70$ km/h

Answer

$$Q_M = Q_{T1} + Q_{T2} + Q_L = 190 + 200 + 50 = 440 \text{ veh/h from Figure A.11}$$

(for no splitter island)

Lower-order turn treatment $'TT_M' = 3.83$ for a BAR

Higher-order turn treatment $'TT_A' = 0$ for a CHR

Using Equation 4.8.1:

$$\begin{aligned} C_{RM} &= 2.75 \times 10^{-12} \times 38974 \times 10 \times 60^{0.406} \times 440^{0.912} \times 70^{2.94} \times (e^{3.83} - e^0) \\ &= \$17,429 \end{aligned}$$

